



PREFORMED LINE PRODUCTS

Section 8 – Line String Hardware

Table of Contents

Clevis Eye & Clevis Eye – 30K	8-2
Rotated Clevis Eye & Clevis Clevis – 30K & 40K.....	8-3
Rotated Clevis Clevis – 30K & Y-Clevis Eye	8-4
Y-Clevis Clevis – 30K & Y-Clevis Eye – 30K	8-5
Rotated Y-Clevis Clevis – 30K & Y-Clevis – Y-Clevis Link	8-6
Ball Clevis & Ball Clevis Link	8-7
Ball Y-Clevis, Ball Y-Clevis Link & Ball Hook	8-8
Socket Clevis, Socket Eye & Socket Eye – 50K.....	8-9
Socket Y-Clevis & Socket Clevis Link – SCL-30 & SCL-50.....	8-10
Socket Y-Clevis Link & Socket Eye Link – 30K	8-11
Eye, Y-Clevis Link – 30K & Chain Link	8-12
Anchor Shackle & Rotated Anchor Shackle	8-13
Rotated Anchor Shackle, BNK & Ball Eye.....	8-14
Ball Eye Hot Line Link & Eye-Eye Hot Line Link – 30K & 50K.....	8-15
7" Eye-Eye Hot Line Link – 30K & Extension Strap	8-16
Vertical Bundling Link for CGS	8-17
Vertical Bundling Link for AGS	8-18
Yoke Plate, Triangle, (APEX Hole) – 40K & 50K.....	8-19
Yoke Plate, Triangle, (APEX Hole) – 50K & 80K.....	8-20
Yoke Plate, Triangle, (APEX Hole) – 100K & 120K.....	8-21
Yoke Plate for Double AGS.....	8-22
Yoke Plate, Rectangle – 30K, 50K & 80K (Per Hole).....	8-23
4" (101mm) Yoke Plate, Delta – 30K & 50K (Per Hole)	8-24
Yoke Plate, Delta – 30K & 100K.....	8-25
Yoke Plate, V-String Twin – 30K & 50K (Per Hole) & Yoke Plate, Medium Angle – 50K (Per Hole).....	8-26
Yoke Plate, Crescent – 30K & 50K (Per Hole)	8-27
Yoke Plate Semi-V 60/30 30K & Yoke Plate Semi-V 78/12 30K (Per Hole).....	8-28
Cross Reference Chart.....	8-29



Transmission Line String Hardware

Clevis Eye

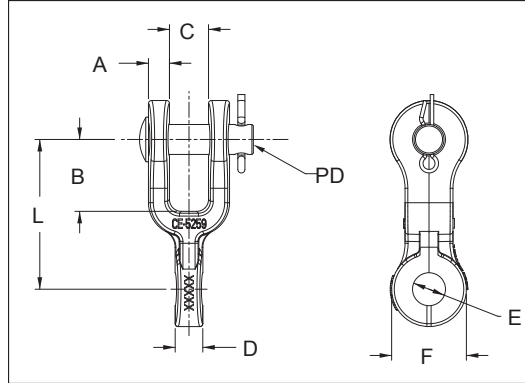
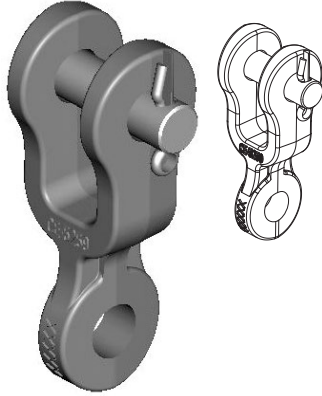

Material	
Body	Ductile iron, hot dip galvanized
Hardware	Galvanized steel
Cotter Pin	Stainless steel

Catalog Number	General Dimensions – inches (mm)								Vertical Ultimate Strength lbf (kN)	Wt. Per 100 Units lbs (kg)
	A	B	C	D	E	F	L	PD		
CE-5259	7/16 (11.2)	1-1/2 (38.1)	13/16 (20.6)	1/2 (17.5)	11/16 (17.5)	1-1/2 (38.1)	3-1/8 (79.4)	5/8 (16)	15,000 (67)	104 (47)
CE-5261	7/16 (11.2)	1-1/2 (38.1)	13/16 (20.6)	3/4 (19.1)	11-1/16 (17.5)	1-1/2 (38.1)	3-1/8 (79.4)	5/8 (16)	20,000 (84)	104 (47)
CE-5105	7/16 (11.2)	1-1/2 (38.1)	13/16 (20.6)	1-1/16 (26.9)	13-16 (20.6)	1-1/2 (38.1)	3-1/8 (79.4)	5/8 (16)	25,000 (111)	105 (48)
CE-5106	7/16 (11.2)	1-1/2 (38.1)	13/16 (20.6)	2-1/8 (54.0)	13-16 (20.6)	1-1/2 (38.1)	3-1/8 (79.4)	5/8 (16)	25,000 (111)	157 (71)
CE-5107	7/16 (11.2)	1-1/2 (38.1)	13/16 (20.6)	1 (25.4)	11/16 (17.5)	1-1/2 (38.1)	3-1/8 (79.4)	5/8 (16)	25,000 (111)	125 (57)

Clevis Eye – 30K

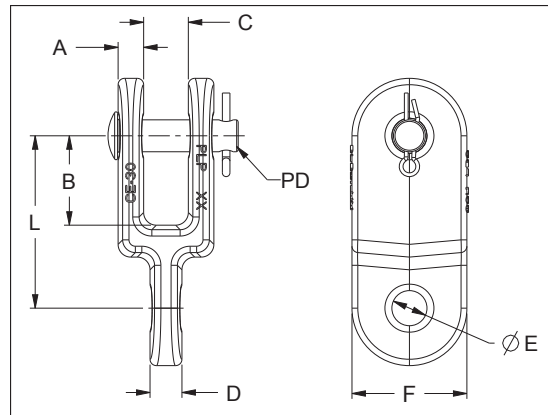
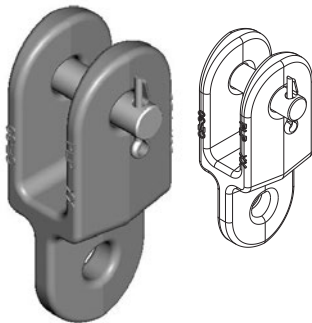

Material	
Body	Ductile iron, hot dip galvanized
Hardware	Galvanized steel
Cotter Pin	Stainless steel

Catalog Number	General Dimensions – inches (mm)								Vertical Ultimate Strength lbf (kN)	Wt. Per 100 Units lbs (kg)
	A	B	C	D	E	F	L	PD		
CE-30	1/2 (12.7)	1-3/4 (44.5)	7/8 (22.2)	5/8 (16)	11/16 (18)	2-1/4 (57.2)	3-3/8 (85.7)	5/8 (16)	30,000 (133)	267 (121)

Transmission Line String Hardware

Rotated Clevis Eye

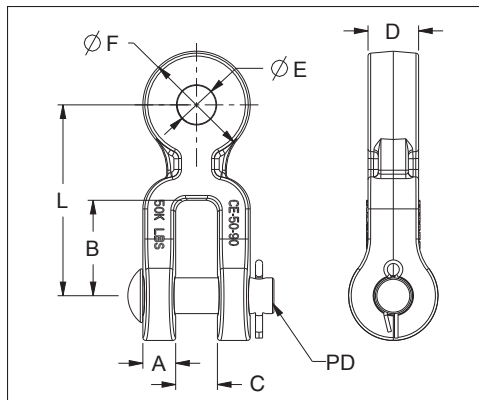
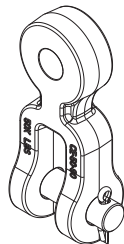

Material	
Body	Ductile iron, hot dip galvanized
Hardware	Galvanized steel
Cotter Pin	Stainless steel

Catalog Number	General Dimensions – inches (mm)								Vertical Ultimate Strength lbf (kN)	Wt. Per 100 Units lbs (kg)
	A	B	C	D	E	F	L	PD		
CE-30-90	1/2 (17.5)	2-1/2 (63.5)	7/8 (22.4)	1-1/16 (26.9)	13/16 (20.6)	2 (50.8)	4-1/2 (114.3)	5/8 (16)	30,000 (133)	180 (82)
CE-50-90	11/16 (17.2)	2 (50.8)	7/8 (22.4)	1-1/16 (26.9)	13/16 (20.6)	2-1/4 (57.2)	4 (101.6)	3/4 (19)	50,000 (222)	280 (127)

Clevis Clevis – 30K & 40K

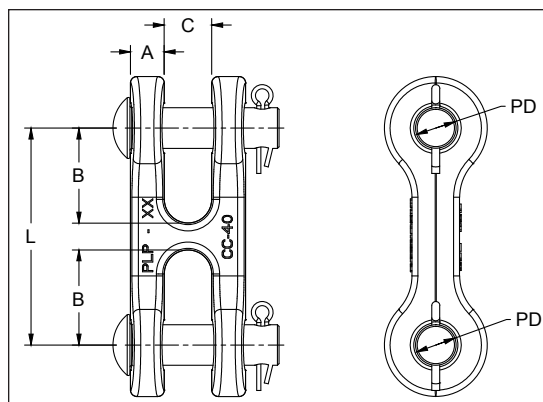
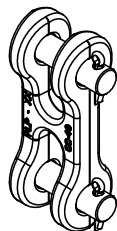

Material	
Body	Forging Steel
Hardware	Galvanized steel
Cotter Pin	Stainless steel

Catalog Number	General Dimensions – inches (mm)					Vertical Ultimate Strength lbf (kN)	Wt. Per 100 Units lbs (kg)
	A	B	C	L	PD		
CC-30	17/32 (13.5)	1-3/4 (44.5)	7/8 (22.2)	4 (101.6)	5/8 (16)	30,000 (133)	1.4 (.65)
CC-40	5/8 (15.9)	1-3/4 (44.5)	7/8 (22.2)	4 (101.6)	5/8 (16)	40,000 (177)	2.8 (1.3)



Transmission Line String Hardware

Rotated Clevis Clevis – 30K

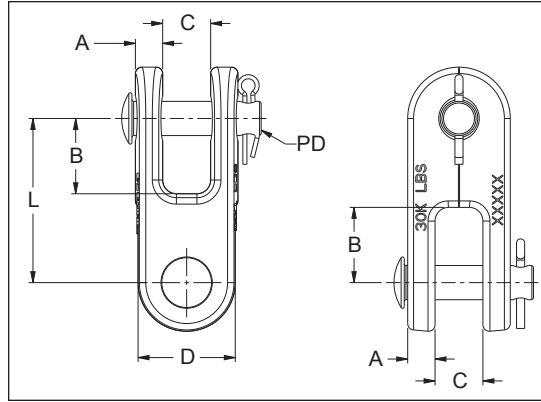
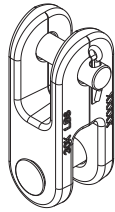
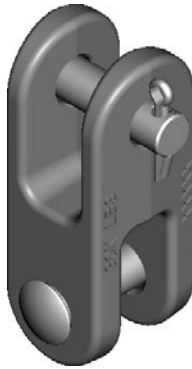

Material	
Body	Ductile iron, hot dip galvanized
Hardware	Galvanized steel
Cotter Pin	Stainless steel

Catalog Number	General Dimensions – inches (mm)						Vertical Ultimate Strength lbf (kN)	Wt. Per 100 Units lbs (kg)
	A	B	C	D	L	PD		
CC-30-90	1/2 (12.7)	1-3/8 (34.9)	7/8 (22.2)	1-25/32 (45.1)	3 (76.2)	5/8 (16)	30,000 (133)	180 (82)

Y-Clevis Eye

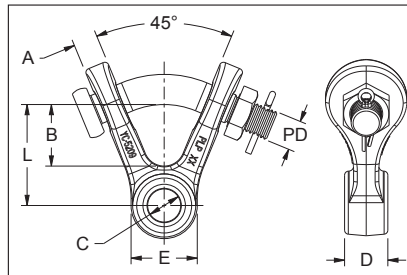
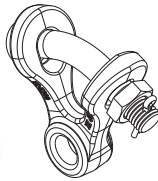

Material	
Body	Ductile iron, hot dip galvanized
Hardware	Galvanized steel
Cotter Pin	Stainless steel

Catalog Number	General Dimensions – inches (mm)							Vertical Ultimate Strength lbf (kN)	Wt. Per 100 Units lbs (kg)
	A	B	C	D	E	L	PD		
YC-5206	19/32 (15)	1-3/4 (44.5)	11/16 (17.5)	5/8 (15.9)	1-5/8 (41.3)	2-19/32 (66)	3/4 (19)	15,000 (67)	104 (47)
YC-5207	19/32 (15)	1-3/4 (44.5)	11/16 (17.5)	3/4 (19)	1-5/8 (41.3)	2-7/16 (61.9)	3/4 (19)	20,000 (84)	104 (47)
YC-5209	19/32 (15)	1-1/2 (38.1)	13/16 (20.6)	1-1/16 (26.9)	1-5/8 (41.3)	2-1/2 (63.5)	3/4 (19)	25,000 (111)	178 (81)
YC-5211	19/32 (15)	1-1/2 (38.1)	13/16 (20.6)	2-1/8 (54.0)	1-5/8 (41.3)	2-1/2 (63.5)	3/4 (19)	25,000 (111)	210 (95)
YC-5212	19/32 (15)	1-1/2 (38.1)	11/16 (17.5)	1 (25.4)	1-5/8 (41.3)	2-1/2 (63.5)	3/4 (19)	25,000 (111)	178 (81)
YCE-50	3/4 (19)	1-19/32 (40.6)	13/16 (20.6)	1-1/8 (28.6)	2 (50.8)	2-19/32 (66)	7/8 (22)	50,000 (222)	280 (127)

Transmission Line String Hardware

Y-Clevis Clevis – 30K

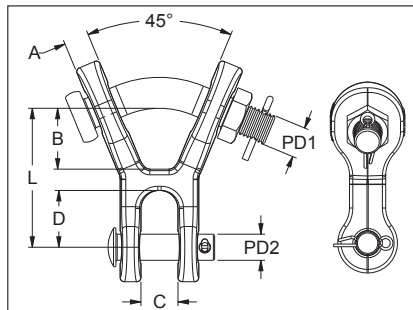
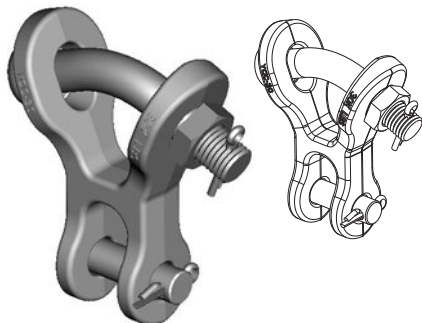

Material	
Body	Ductile iron, hot dip galvanized
Hardware	Galvanized steel
Cotter Pin	Stainless steel

Catalog Number	General Dimensions – inches (mm)							Vertical Ultimate Strength lbf (kN)	Wt. Per 100 Units lbs (kg)
	A	B	C	D	L	PD1	PD2		
YCC-30	19/32 (15)	1-15/32 (37)	7/8 (23)	1-3/8 (35)	3-5/16 (84)	3/4 (19)	5/8 (16)	30,000 (133)	270 (120)

Y-Clevis Eye – 30K

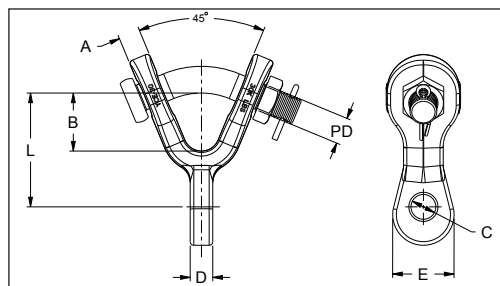
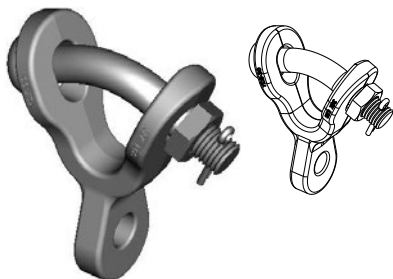

Material	
Body	Ductile iron, hot dip galvanized
Hardware	Galvanized steel
Cotter Pin	Stainless steel

Catalog Number	General Dimensions – inches (mm)							Vertical Ultimate Strength lbf (kN)	Wt. Per 100 Units lbs (kg)
	A	B	C	D	E	L	PD		
YCE-30	19/32 (15)	1-3/4 (44.5)	11/16 (17.5)	5/8 (15.9)	1-11/16 (42.8)	3-5/32 (80.2)	3/4 (19)	30,000 (133)	1.6 (.73)



Transmission Line String Hardware

Rotated Y-Clevis Clevis – 30K

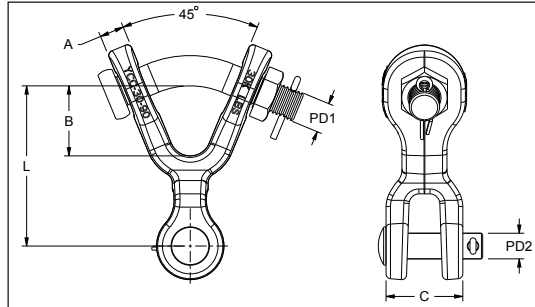
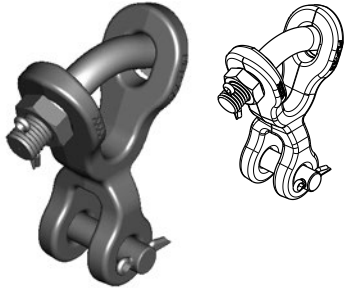

Material	
Body	
Hardware	Galvanized steel
Cotter Pin	

Catalog Number	General Dimensions – inches (mm)							Vertical Ultimate Strength lbf (kN)	Wt. Per 100 Units lbs (kg)
	A	B	C	D	L	PD1	PD2		
YCC-30-90	19/32 (15.2)	1-3/4 (44.5)	1-7/8 (47.6)	1.36 (35)	3-29/32 (99.4)	3/4 (19)	5/8 (16)	30,000 (133)	3.25 (1.47)

Y-Clevis – Y-Clevis Link

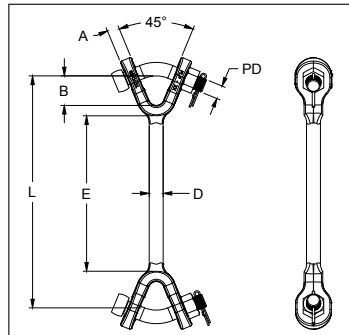
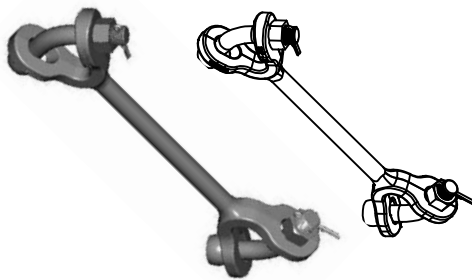

Material	
Body	Forged steel, hot dip galvanized
Hardware	Galvanized steel
Cotter Pin	Stainless steel

Catalog Number	General Dimensions – inches (mm)						Vertical Ultimate Strength lbf (kN)	Wt. Per 100 Units lbs (kg)
	A	B	D	E	L	PD		
YCYC-50	3/4 (19)	1-1/2 (38.1)	Ø 7/8 (22.2)	10 (253.5)	14-5/16 (363.4)	15/16 (23.5)	50,000 (222)	6.75 (3.06)

Transmission Line String Hardware

Ball Clevis

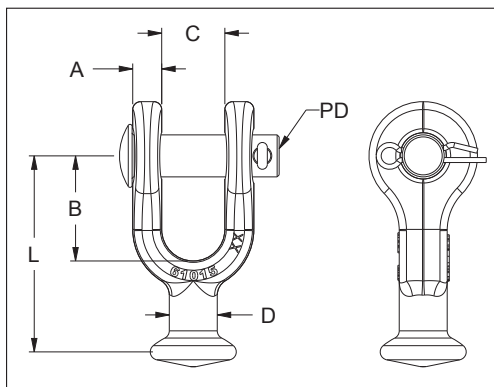
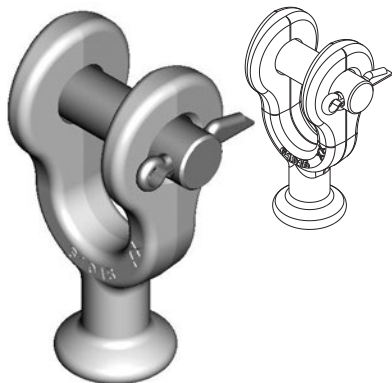

Material	
Body	Ductile iron, hot dip galvanized
Hardware	Galvanized steel
Cotter Pin	Stainless steel

Catalog Number	General Dimensions inches (mm)						For Use with Insulators per ANSI Class Spec. C-29.2-71	Vertical Ultimate Strength lbf (kN)	Wt. Per 100 Units lbs (kg)
	A	B	C	D	L	PD			
BC-30	7/16 (11)	1-9/16 (39.7)	15/16 (24)	11/16 (18)	2-15/16 (74)	5/8 (16)	52-3 and 52-5	30,000 (133)	97 (44)
BC-50	5/8 (16)	1-15/16 (49.2)	15/16 (24)	7/8 (22.6)	4-3/8 (111)	3/4 (19)	52-8 and 52-11	50,000 (222)	214 (97)

Ball Clevis Link

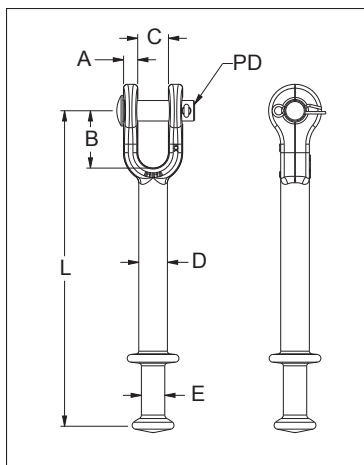
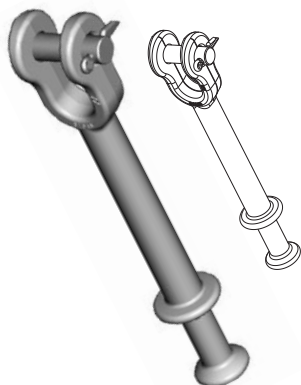

Material	
Body	Forging steel, hot dip galvanized
Hardware	Galvanized steel
Cotter Pin	Stainless steel

Catalog Number	General Dimensions inches (mm)							For Use with Insulators per ANSI Class Spec. C-29.2-71	Vertical Ultimate Strength lbf (kN)	Wt. Per 100 Units lbs (kg)
	A	B	C	D	E	L	PD			
BCL-30	7/16 (11)	1-3/4 (44.5)	15/16 (24)	7/8 (22.2)	11/16 (18)	9-5/8 (15.9)	5/8 (16)	52-3 and 52-5	30,000 (133)	219 (100)
BCL-50	9/16 (14.3)	1-3/4 (44.5)	15/16 (24)	15/16 (24)	7/8 (22.6)	10-1/8 (25.6)	7/8 (22)	52-8 and 52-11	50,000 (222)	281 (130)



Transmission Line String Hardware

Ball Y-Clevis

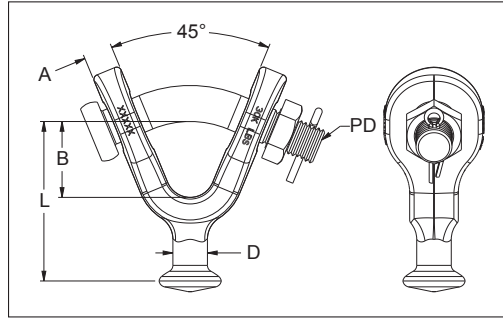

Material	
Body	Forged steel, hot dip galvanize
Hardware	Galvanized steel
Cotter Pin	Stainless steel

Catalog Number	General Dimensions inches (mm)					For Use with Insulators per ANSI Class Spec. C-29.2-71	Vertical Ultimate Strength lbf (kN)	Wt. Per 100 Units lbs (kg)
	A	B	D	L	PD			
BYC-30	7/16 (11)	1-9/16 (39.7)	11/16 (18)	3-1/4 (83)	3/4 (19)	52-3 and 52-5	30,000 (133)	220 (100)
BYC-50	5/8 (16)	1-5/8 (41.1)	7/8 (22.6)	4 (101.6)	7/8 (22)	52-8 and 52-11	50,000 (222)	400 (180)

Ball Y-Clevis Link

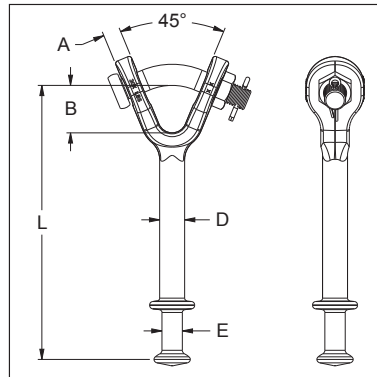
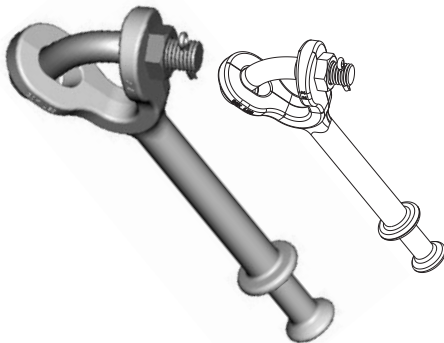

Material	
Body	Forged steel, hot dip galvanize
Hardware	Galvanized steel
Cotter Pin	Stainless steel

Catalog Number	General Dimensions inches (mm)						For Use with Insulators per ANSI Class Spec. C-29.2-71	Vertical Ultimate Strength lbf (kN)	Wt. Per 100 Units lbs (kg)
	A	B	D	E	L	PD			
BYCL-30	5/8 (16)	1-11/16 (42.7)	7/8 (22.2)	11/16 (18)	9-5/8 (244)	3/4 (19)	52-3 and 52-5	30,000 (133)	337 (152)
BYCL-50	3/4 (19)	1-5/8 (41.1)	15/16 (24)	7/8 (22.6)	11 (279)	7/8 (22.6)	52-8 and 52-11	50,000 (222)	546 (250)

Ball Hook

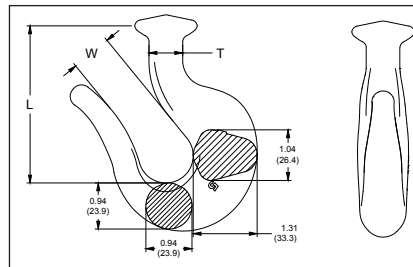
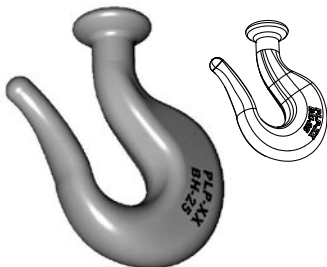

Material	
Body	Forged steel, hot dip galvanize

Catalog Number	General Dimensions inches (mm)			For Use with Insulators per ANSI Class Spec. C-29.2-71	Vertical Ultimate Strength lbf (kN)	Wt. Per 100 Units lbs (kg)
	L	W	T			
BH-25	3-7/32 (81.7)	7/8 (22.4)	11/16 (17.5)	52-3 and 52-5	25,000 (111)	1.40 (0.64)

Transmission Line String Hardware

Socket Clevis

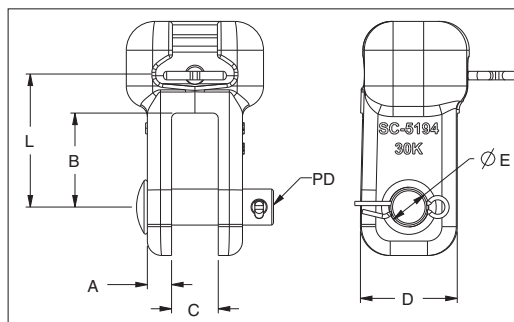
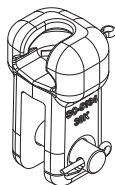
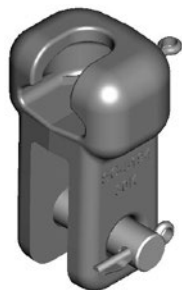

Material

Body: Ductile iron,
hot dip galvanize
Hardware: Galvanized steel
Cotter Pin: Stainless steel

Catalog Number	General Dimensions inches (mm)							For Use with Insulators per ANSI Class Spec. C-29.2-71	Vertical Ultimate Strength lbf (kN)	Wt. Per 100 Units lbs (kg)
	A	B	C	D	E	L	PD			
SC-5194	7/16 (11.1)	1-5/8 (41.3)	13/16 (20.6)	1-3/4 (44.5)	11/16 (17.5)	2-5/8 (66.7)	5/8 (16)	52-3 and 52-5	30,000 (133)	200 (90)
SC-50	11/16 (17.5)	2-1/32 (51.6)	1-1/8 (28.6)	2-1/16 (52.8)	15/16 (23.8)	2-11/16 (68.3)	7/8 (22)	52-8 and 52-11	50,000 (222)	460 (208)

Socket Eye

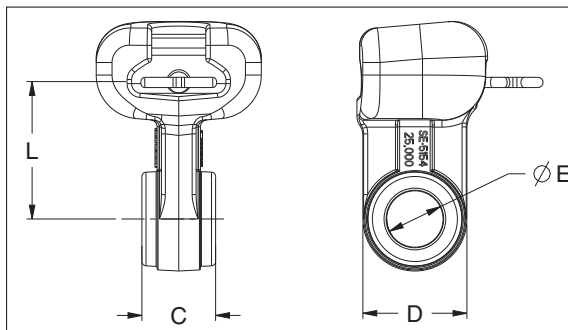
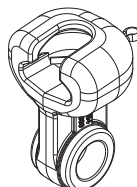

Material

Body: Ductile iron,
hot dip galvanize
Cotter Pin: Stainless steel

Catalog Number	General Dimensions inches (mm)				For Use with Insulators per ANSI Class Spec. C-29.2-71	Vertical Ultimate Strength lbf (kN)	Wt. Per 100 Units lbs (kg)
	C	D	E	L			
SE-5150	1/2 (12.7)	1-1/2 (38.1)	11/16 (17.5)	2-5/16 (58.8)	52-3 and 52-5	15,000 (67)	165 (75)
SE-5152	3/4 (19.1)	1-1/2 (38.1)	11/16 (17.5)	2-5/16 (58.8)		20,000 (84)	165 (75)
SE-5154	1-1/16 (26.9)	1-1/2 (38.1)	13/16 (20.6)	2-5/16 (58.8)		25,000 (111)	178 (81)
SE-5155	2-1/8 (54)	1-1/2 (38.1)	13/16 (20.6)	2-5/16 (58.8)		30,000 (133)	178 (81)
SE-5156	1 (25.4)	1-1/2 (38.1)	11/16 (17.5)	1-15/16 (49.0)		25,000 (111)	144 (65)
SE-5157	1-1/8 (28.6)	1-3/4 (44.5)	11/16 (17.5)	2-1/16 (52.3)		30,000 (133)	168 (76)
SE-5158	3-1/4 (82.6)	2 (50.8)	25/32 (19.8)	2-29/32 (73.9)	52-8 and 52-11	50,000 (222)	438 (199)

Socket Eye – 50K

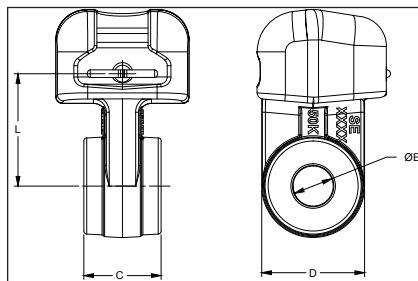
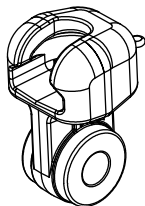

Material

Body	Ductile iron, hot dip galvanize
Cotter Pin	Stainless steel

Catalog Number	General Dimensions inches (mm)				For Use with Insulators per ANSI Class Spec. C-29.2-71	Vertical Ultimate Strength lbf (kN)	Wt. Per 100 Units lbs (kg)
	C	D	E	L			
SE-9002	1-1/2 (38.1)	2 (50.8)	25/32 (19.8)	2-3/16 (55.4)	52-8 and 52-11	50,000 (111)	297 (135)



Transmission Line String Hardware

Socket Y-Clevis

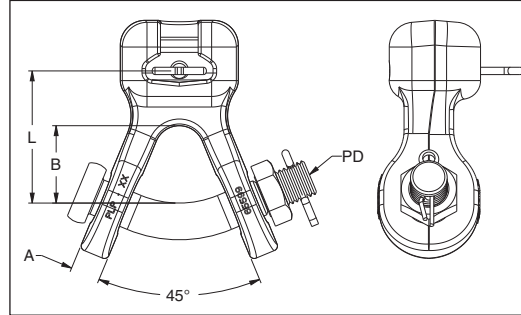
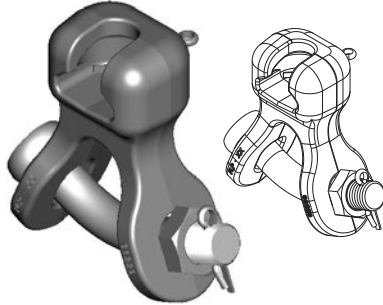

Material	
Body	Ductile iron, hot dip galvanize
Hardware	Galvanized steel
Cotter Pin	Stainless steel

Catalog Number	General Dimensions inches (mm)				For Use with Insulators per ANSI Class Spec. C-29.2-71	Vertical Ultimate Strength lbf (kN)	Wt. Per 100 Units lbs (kg)
	A	B	L	PD			
SYC-30	5/8 (16)	1-9/16 (39.7)	2-3/4 (69.8)	3/4 (19)	52-3 and 52-5	30,000 (133)	310 (140)
SYC-50	3/4 (19)	1-5/8 (41.1)	2-5/16 (58.7)	7/8 (22)	52-8 and 52-11	50,000 (222)	470 (210)

Socket Clevis Link – SCL-30 & SCL-50

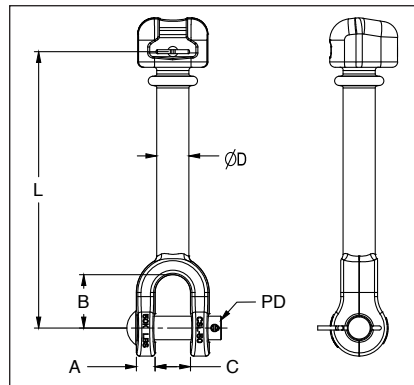
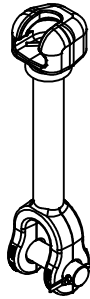
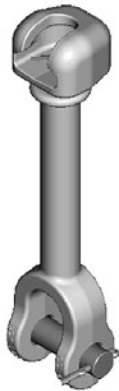

Material	
Body	Ductile iron, hot dip galvanize
Hardware	Galvanized steel
Cotter Pin	Stainless steel

Catalog Number	General Dimensions inches (mm)						For Use with Insulators per ANSI Class Spec. C-29.2-71	Vertical Ultimate Strength lbf (kN)	Wt. Per 100 Units lbs (kg)
	A	B	C	D	L	PD			
CSL-30	7/16 (11.0)	1-9/16 (39.7)	1 (25.4)	11/16 (18)	3/4 (69.5)	3/4 (19)	52-3 and 52-5	30,000 (133)	2.9 (1.3)
CSL-50	11/16 (17.5)	1-5/8 (41.1)	1-5/16 (33.4)	1-3/16 (30.2)	2-5/16 (58.7)	7/8 (22)	52-8 and 52-11	50,000 (222)	5.3 (2.5)

Transmission Line String Hardware

Socket Y-Clevis Link

For use with Class 52-3 and 52-5 insulators per ANSI Spec C-29.2-71.

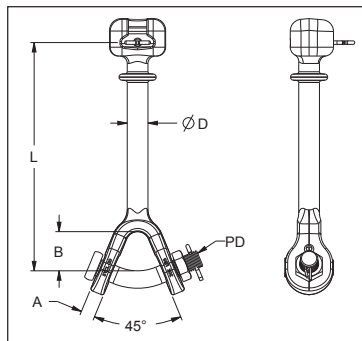
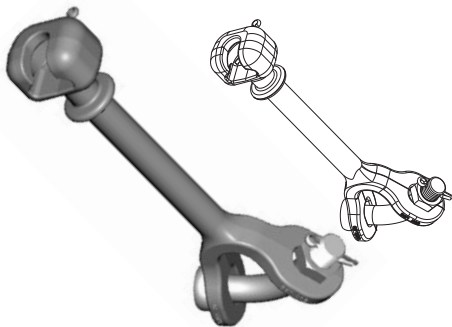

Material	
Body	Ductile iron, hot dip galvanize
Hardware	Galvanized steel
Cotter Pin	Stainless steel

Catalog Number	General Dimensions inches (mm)					For Use with Insulators per ANSI Class Spec. C-29.2-71	Vertical Ultimate Strength lbf (kN)	Wt. Per 100 Units lbs (kg)
	A	B	D	L	PD			
SYCL-30	5/8 (16)	1-11/16 (42.2)	7/8 (22.4)	9-11/16 (246)	3/4 (19)	52-3 and 52-5	30,000 (133)	410 (190)
SYCL-50	3/4 (19)	1-5/8 (41.1)	1-3/16 (30.2)	10-5/16 (262)	7/8 (22)	52-8 and 52-11	50,000 (222)	730 (330)

Socket Eye Link – 30K – Catalog No. SEL-30

For use with Class 52-3 and 52-5 insulators per ANSI Spec C-29.2-71.

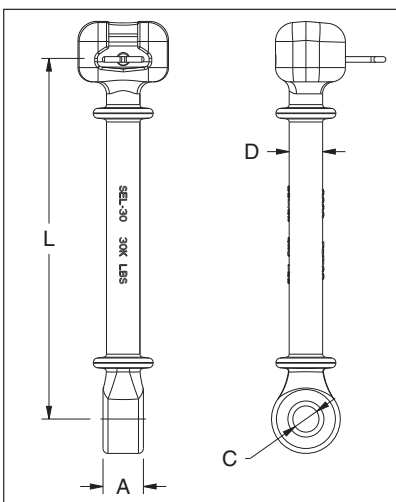
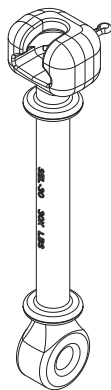

Material	
Body	Ductile iron, hot dip galvanize
Cotter Pin	Stainless steel

Catalog Number	General Dimensions – inches (mm)				Vertical Ultimate Strength lbf (kN)	Wt. Per 100 Units lbs (kg)
	A	C	D	L		
SEL-30	1-1/16 (27)	11/16 (17.5)	7/8 (22.4)	9-15/32 (240.3)	30,000 (133)	300 (136)



Transmission Line String Hardware

Eye, Y-Clevis Link – 30K

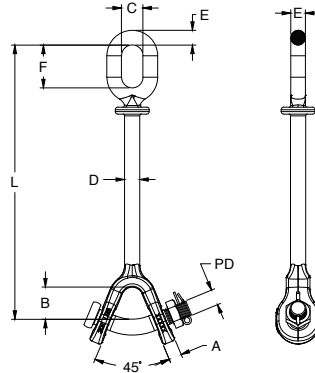
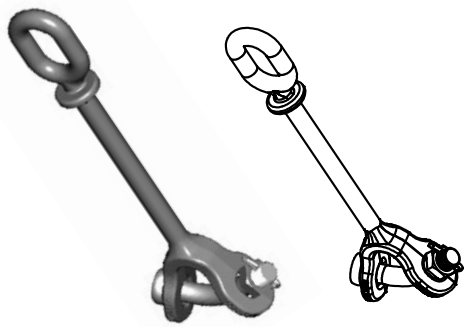

Material	
Body	Galvanize steel
Cotter Pin	

Catalog Number	General Dimensions inches (mm)								Vertical Ultimate Strength lbf (kN)	Wt. Per 100 Units lbs (kg)
	A	B	C	D	E	F	L	PD		
EYCL-30-12	19/32 (15.2)	1-1/2 (39.3)	1 (24.5)	11/16 (18)	11/16 (17.5)	2 (50.9)	12-13/16 (325.7)	3/4 (19)	30,000 (133)	3.2 (1.5)

Chain Link

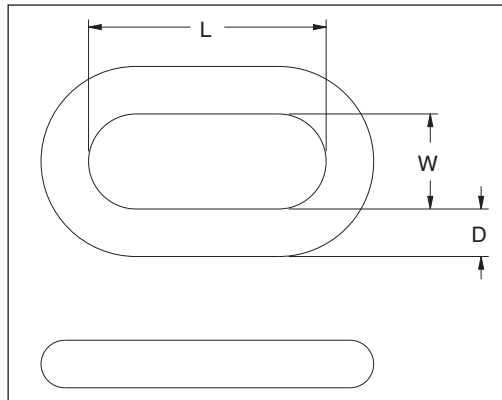
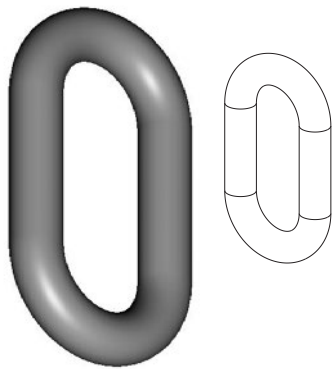

Material	
Material	Forged steel, hot dip galvanize

Catalog Number	General Dimensions – inches (mm)			Vertical Ultimate Strength lbf (kN)	Wt. Per 100 Units lbs (kg)
	L	W	D		
CL-30	2-1/2 (63.5)	1 (25.4)	19/32 (15.0)	30,000 (133)	40 (20)
CL-60	3-1/2 (88.9)	1 (25.4)	13/16 (21.0)	60,000 (267)	130 (60)
CL-80	4 (101.6)	1-1/4 (31.8)	31/32 (24.5)	80,000 (356)	210 (100)
CL-100	5 (127.0)	1-1/4 (31.8)	1-3/32 (27.5)	100,000 (445)	320 (150)
CL-120	6 (152.4)	1-1/2 (38.1)	1-3/16 (30.0)	120,000 (534)	610 (280)

Transmission Line String Hardware

Anchor Shackle

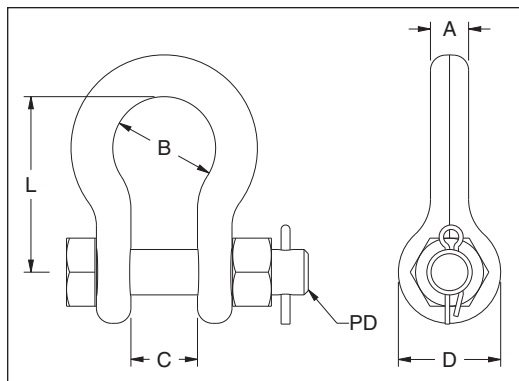
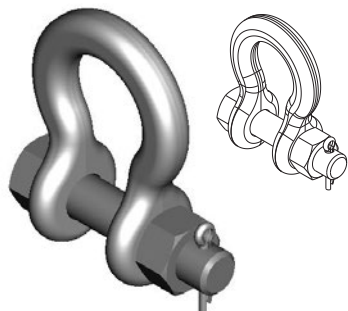

Material	
Body	Forged steel, hot dip galvanize
Hardware	Galvanized steel
Cotter Pin	Stainless steel

Catalog Number	General Dimensions – inches (mm)						Vertical Ultimate Strength lbf (kN)	Wt. Per 100 Units lbs (kg)
	A	B	C	D	L	PD		
AS-30-BNK	17/32 (13.5)	1-1/4 (31.8)	15/16 (23.4)	1-1/4 (31.8)	2-3/4 (70)	5/8 (16)	30,000 (133)	100 (45)
AS-50-BNK	5/8 (16)	1-11/16 (43)	1-1/8 (28)	1-11/16 (43)	2-29/32 (74)	3/4 (19)	50,000 (222)	290 (132)
AS-70-BNK	3/4 (19.1)	2 (51)	1-15/16 (33)	2 (51)	3-19/32 (91)	7/8 (22)	70,000 (311)	318 (144)
AS-100-BNK	1-1/8 (28.4)	2-1/4 (57)	1-21/32 (41.6)	2-1/4 (57)	3-19/32 (91)	1-1/8 (28)	100,000 (445)	500 (227)

Rotated Anchor Shackle

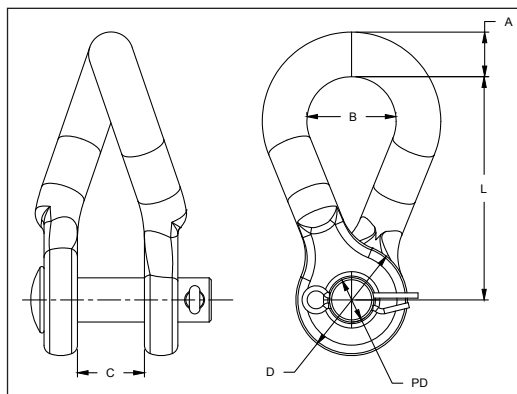
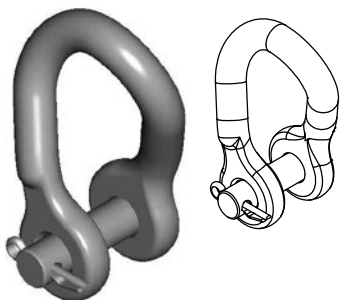

Material	
Body	Forged steel, hot dip galvanize
Hardware	Galvanized steel
Cotter Pin	Stainless steel

Catalog Number	General Dimensions – inches (mm)						Vertical Ultimate Strength lbf (kN)	Wt. Per 100 Units lbs (kg)
	A	B	C	D	L	PD		
AS-25-90	5/8 (16)	1-1/4 (32)	1 (24)	Ø1-5/8 (40)	3-1/8 (80)	Ø5/8 (17)	25,000 (111)	140 (64)



Transmission Line String Hardware

Rotated Anchor Shackle, BNK

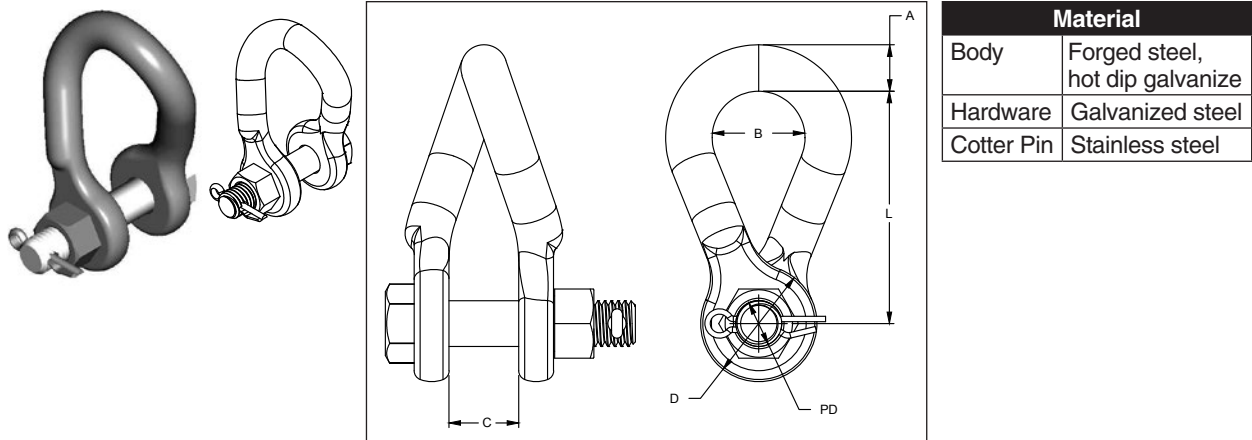

Material	
Body	Forged steel, hot dip galvanize
Hardware	Galvanized steel
Cotter Pin	Stainless steel

Catalog Number	General Dimensions inches (mm)						Vertical Ultimate Strength lbf (kN)	Wt. Per 100 Units lbs (kg)
	A	B	C	D	L	PD		
AS-25-90BNK	5/8 (16)	1-1/4 (32)	1 (24)	Ø1-5/8 (40)	3-1/8 (80)	Ø5/8 (17)	25,000 (111)	140 (64)

Ball Eye

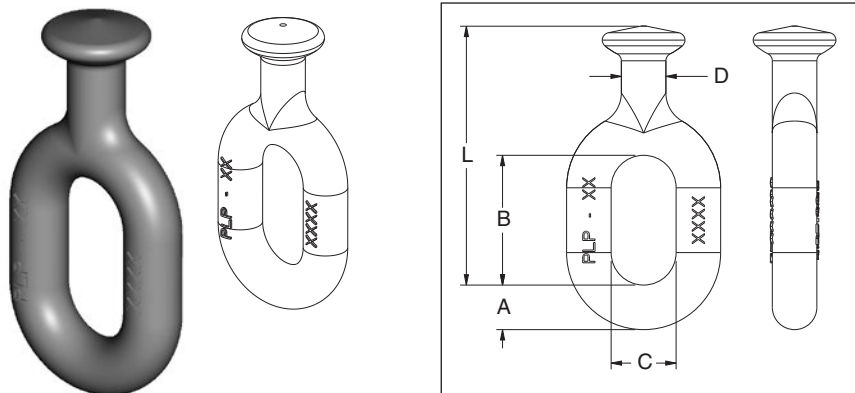

Material	
Material	Forged steel, hot dip galvanize

Catalog Number	General Dimensions inches (mm)					For Use with Insulators per ANSI Class Spec. C-29.2-71	Vertical Ultimate Strength lbf (kN)	Wt. Per 100 Units lbs (kg)
	A	B	C	D	L			
BE-30	11/16 (17.5)	2 (51)	1 (25.4)	11/16 (17.5)	4 (101.6)	52-3 and 52-5	30,000 (133)	100 (45)
BE-50	3/4 (19)	2-1/2 (63.5)	1-1/4 (31.8)	7/8 (22.6)	4-13/16 (122.2)	52-8 and 52-11	50,000 (222)	150 (68)

Transmission Line String Hardware

Ball Eye Hot Line Link, 30K and 50K

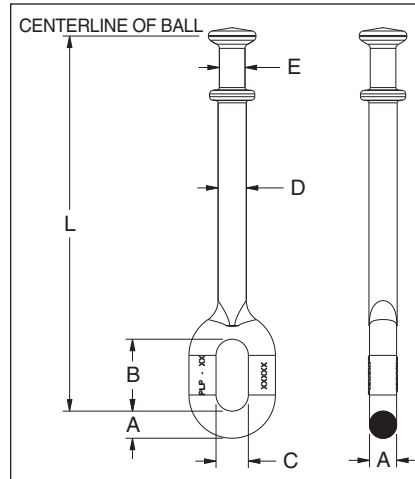
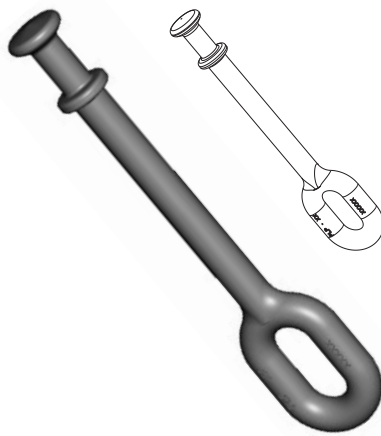

Material
Forged steel, hot dip galvanize

Catalog Number	General Dimensions inches (mm)						For Use with Insulators per ANSI Class Spec. C-29.2-71	Vertical Ultimate Strength lbf (kN)	Wt. Per 100 Units lbs (kg)
	A	B	C	D	E	L			
BEL-30-L	11/16 (17.5)	2-1/8 (53.9)	15/16 (24)	7/8 (22.4)	23/32 (18)	TBD	52-3 and 52-5	30,000 (133)	320 (45)
BEL-50-L	15/16 (23.9)	2-1/2 (63.4)	1-1/8 (28.5)	31/32 (24.9)	7/8 (22.6)	TBD	52-8 and 52-11	50,000 (222)	475 (216)

Eye-Eye Hot Line Link, 30K and 50K

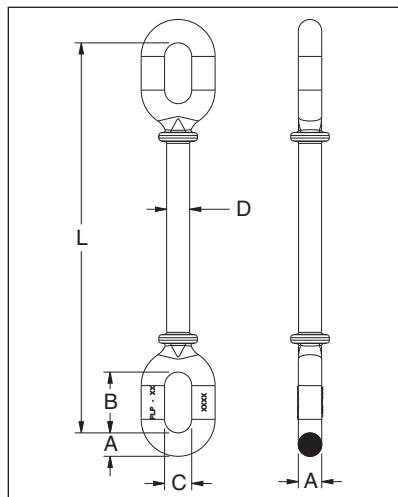
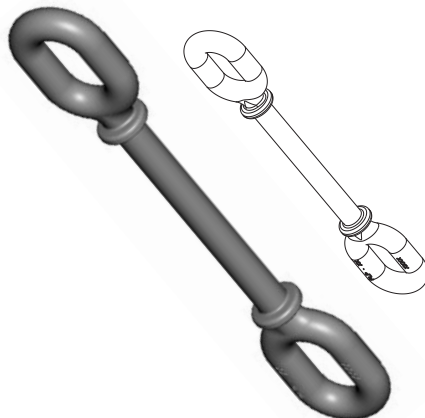

Material
Forged steel, hot dip galvanize

Catalog Number	General Dimensions – inches (mm)					Vertical Ultimate Strength lbf (kN)
	A	B	C	D	L	
EEL-30-L	11/16 (17.5)	2-1/8 (53.9)	15/16 (23.7)	7/8 (22.4)	TBD	30,000 (133)
EEL-50-L	15/16 (23.9)	2-1/2 (63.4)	1-1/8 (28.5)	31/32 (24.9)	TBD	50,000 (222)



Transmission Line String Hardware

7" (177mm) Eye-Eye Hot Line Link, 30K

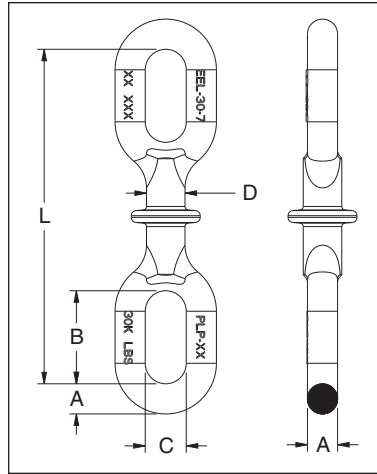
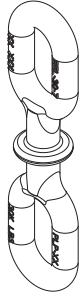

Material
Forged steel, hot dip galvanize

Catalog Number	General Dimensions – inches (mm)					Vertical Ultimate Strength lbf (kN)	Wt. Per 100 Units lbs (kg)
	A	B	C	D	L		
EEL-30-7	11/16 (17.5)	2-1/8 (54)	15/16 (23.8)	7/8 (22.4)	7-5/8 (194.1)	30,000 (133)	100 (45)

Extension Strap

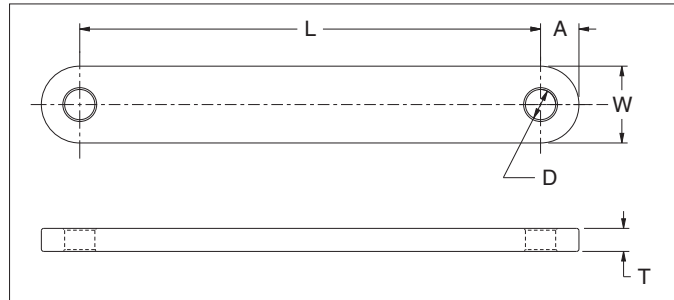
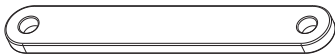

Material
Galvanized steel

Catalog Number	General Dimensions – inches (mm)					Ultimate Strength (lbs)	Vertical Ultimate Strength lbf (kN)	Wt. Per 100 Units lbs (kg)
	A	D	L	W	T			
ES-30-L (xx) (l = length)	1 (25.4)	7/8 (22)	TBD	2 (50.8)	3/4 (19.1)	30,000 (133)	30,000 (133)	100 (45)
ES-50-L (xx) (l = length)	1-1/4 (31.8)	31/32 (25)	TBD	2-1/4 (63.5)	3/4 (19.1)	50,000 (222)	50,000 (222)	750 (340)

Transmission Line String Hardware

Vertical Bundling Link for CGS – Catalog No. VBL-MS-11244 and VBL-MS-11302

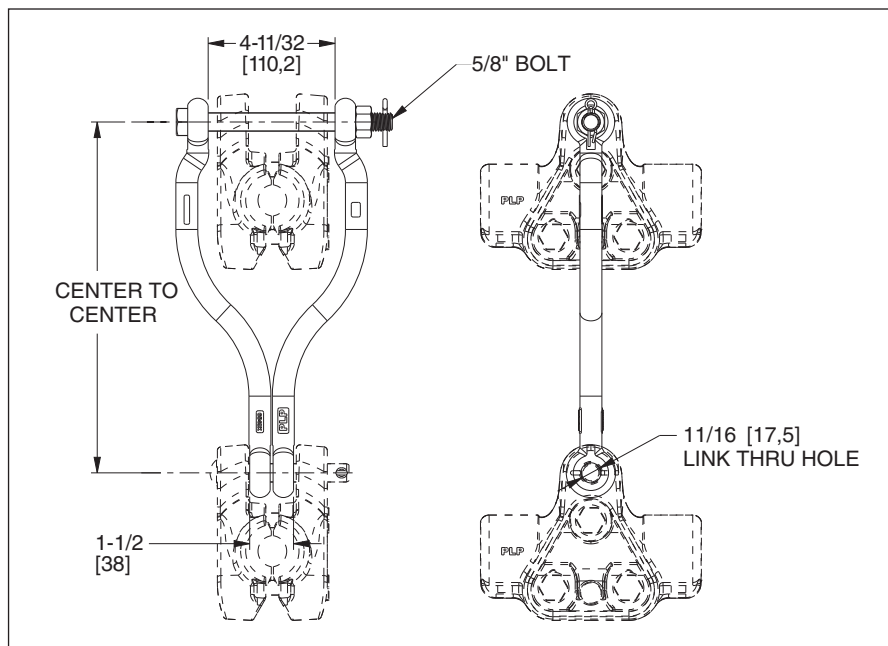
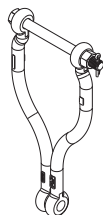

Catalog Number	CGS Range	Center to Center	Vertical Ultimate Strength lbf (kN)	Wt. Per 100 Units lbs (kg)
VBL-MS-11244	All Sizes	12 (305)	30,000 (133)	6.2 (2.81)
VBL-MS-11302	All Sizes	18 (457)	40,000 (222)	7.5 (3.4)

Material	
Link	Forged steel, hot dip galvanize
Hardware	Galvanized steel
Cotter Pin	Stainless steel



Transmission Line String Hardware

Vertical Bundling Link for AGS

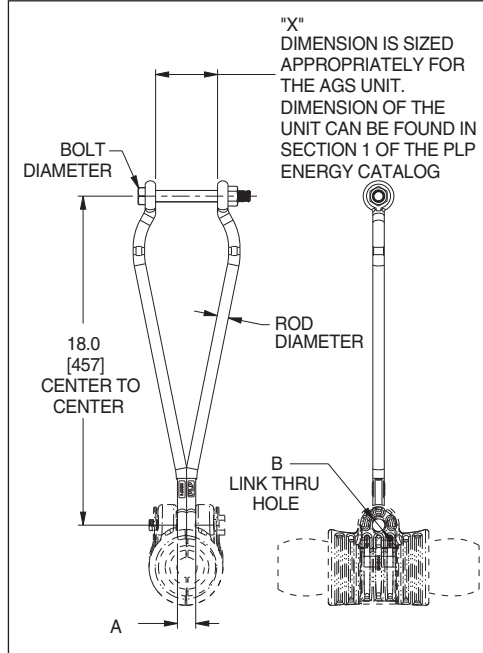
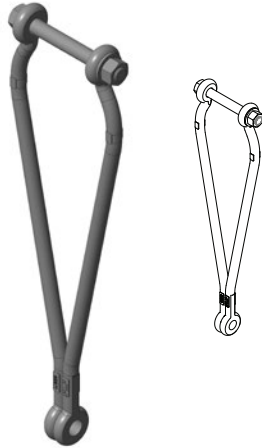

Material	
Link	Forged steel, hot dip galvanize
Hardware	Galvanized steel

Catalog Number	AGS Range inches (mm)	General Dimensions – inches (mm)					Wt. Per 100 Units lbs (kg)
		Rod Diameter inches (mm)	Bolt Diameter inches (mm)	Center to Center inches (mm)	A	B	
VBL-04	.751-.907 (19.0-23.0)	5/8 (15.8)	5/8 (15.8)	18 (457)	1 (25)	11/16 (17.5)	390 (177)
VBL-05	.908-1.005 (23.0-25.5)	5/8 (15.8)	5/8 (15.8)	18 (457)	1 (25)	11/16 (17.5)	390 (177)
VBL-06	1.006-1.208 (25.5-30.6)	5/8 (15.8)	5/8 (15.8)	18 (457)	1 (25)	11/16 (17.5)	392 (178)
VBL-07	1.209-1.355 (30.6-34.4)	3/4 (19.0)	3/4 (19.0)	18 (457)	1-3/8 (36)	13/16 (20.6)	582 (265)
VBL-08	1.356-1.557 (34.4-39.54)	3/4 (19.0)	3/4 (19.0)	18 (457)	1-3/8 (36)	13/16 (20.6)	612 (278)
VBL-09	1.558-1.882 (39.54-47.80)	3/4 (19.0)	3/4 (19.0)	18 (457)	1-3/8 (36)	13/16 (20.6)	612 (278)
VBL-10	1.883-2.233 (47.80-56.71)	3/4 (19.0)	3/4 (19.0)	18 (457)	1-3/8 (36)	13/16 (20.6)	612 (278)

Also available in 12" (304 mm) vertical spacing. Add -12 to catalog number (example: VBL-06-12).
 Each assembly consists of two links, one bolt for top AGS, one lock washer and one locknut.

Transmission Line String Hardware

Yoke Plate, Triangle, 40K (APEX Hole) – Catalog No. YPD-65597

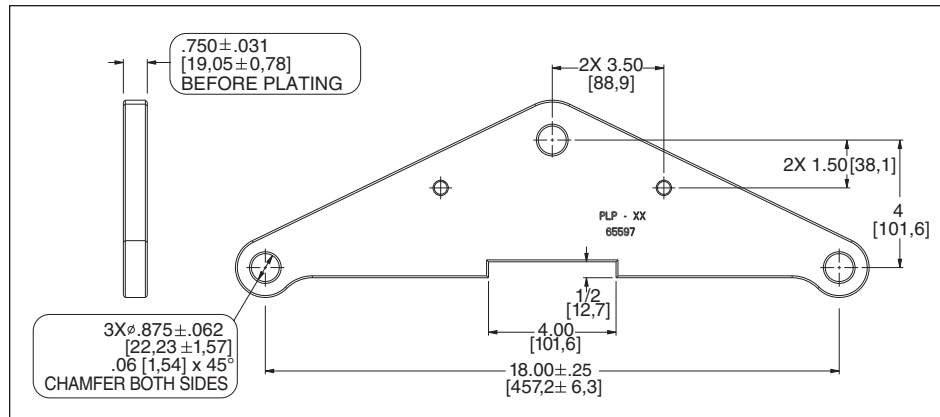
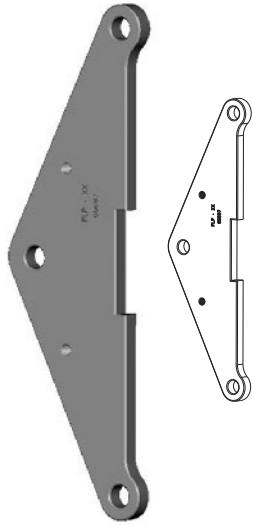

Notes

Material	Galvanized steel
Approximate weight	13 lbs (5.9 kg)
Rated breaking strength (RBS)	40,000 lbs (APEX Hole) (178 kN)

Yoke Plate, Triangle, 50K (APEX Hole) – Catalog No. YPD-65607

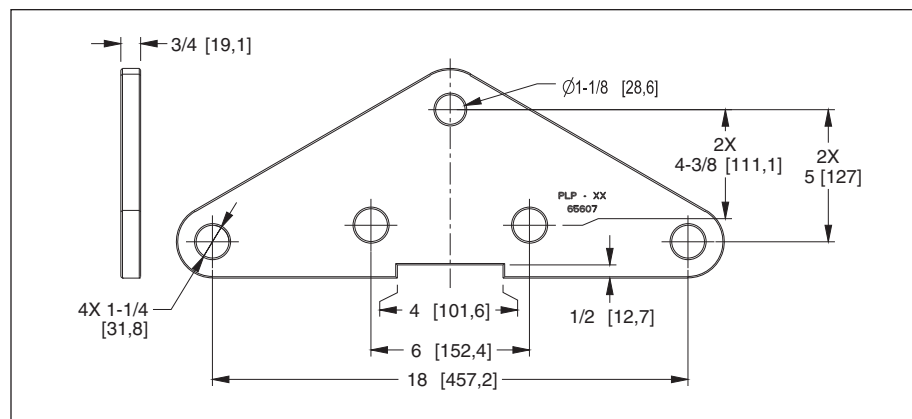
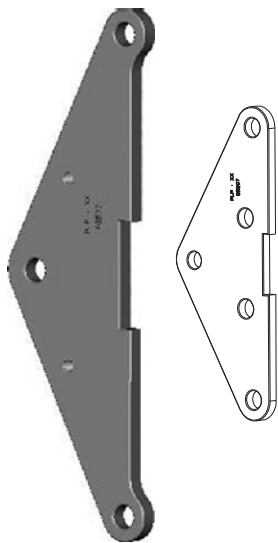

Notes

Material	Galvanized steel
Approximate weight	21 lbs (9.5 kg)
Rated breaking strength (RBS)	50,000 lbs (APEX Hole) (222 kN)



Transmission Line String Hardware

Yoke Plate, Triangle, 50K (APEX Hole) – Catalog No. YPD-65961

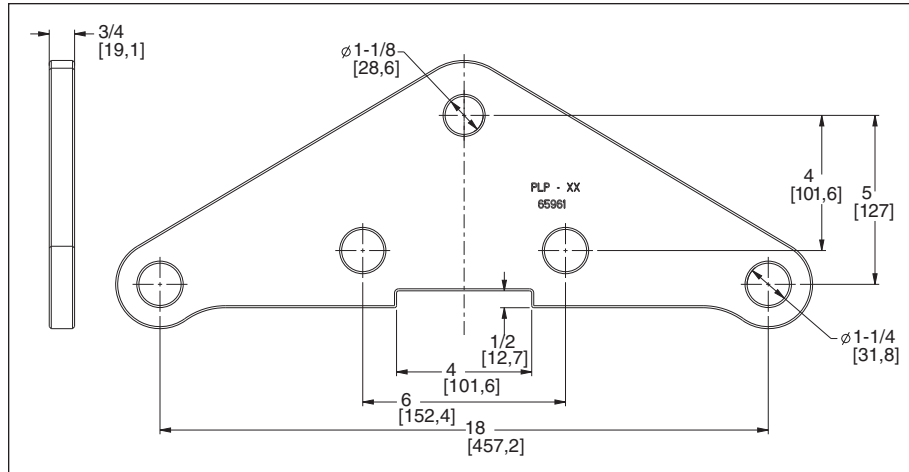
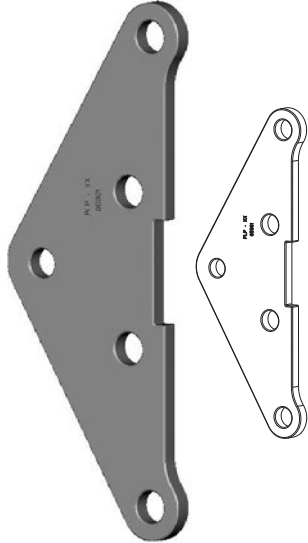

Notes	
Material	Galvanized steel
Approximate weight	18 lbs (8.2 kg)
Rated breaking strength (RBS)	50,000 lbs (APEX Hole) (222 kN)

Yoke Plate, Triangle, 80K (APEX Hole) – Catalog No. YPD-65998

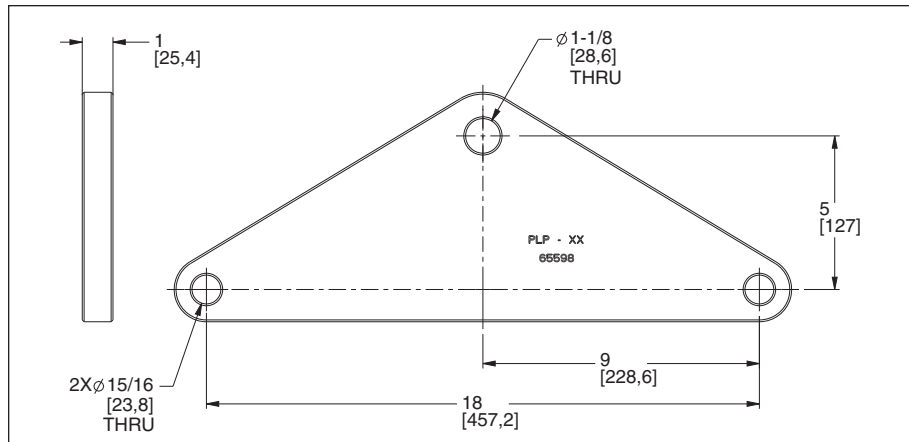
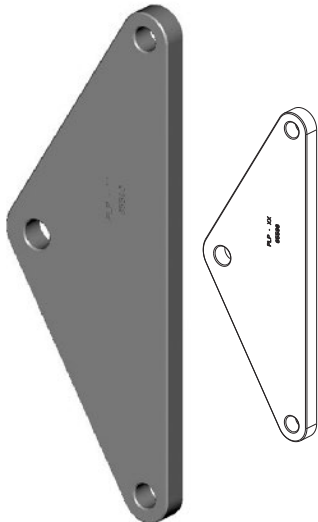

Notes	
Material	Galvanized steel
Approximate weight	26 lbs (11.3 kg)
Rated breaking strength (RBS)	80,000 lbs (APEX Hole) (356 kN)

Transmission Line String Hardware

Yoke Plate, Triangle, 100K (APEX Hole) – Catalog No. YPD-65965

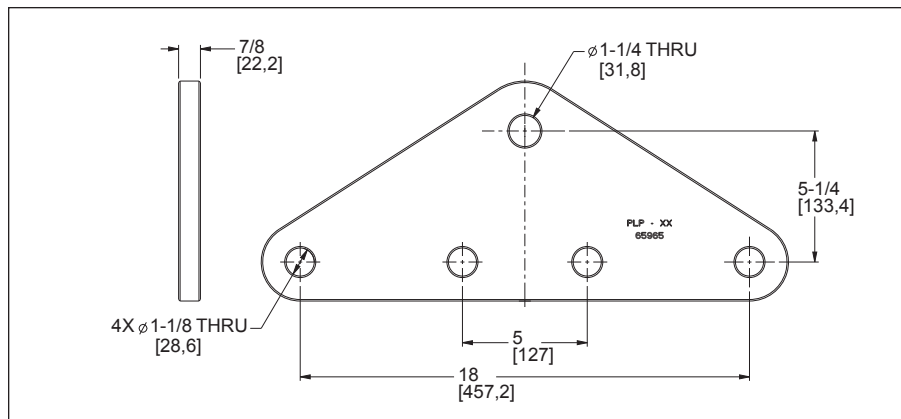
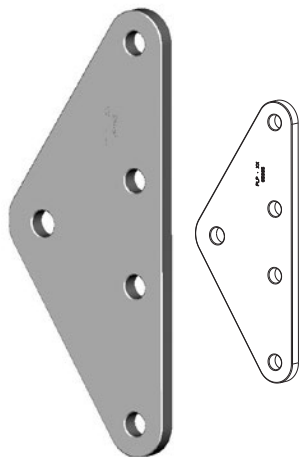

Notes

Material	Galvanized steel
Approximate weight	29 lbs (13.2 kg)
Rated breaking strength (RBS)	100,000 lbs (APEX Hole) (444 kN)

Yoke Plate, Triangle, 120K (APEX Hole) – Catalog No. YPD-65616

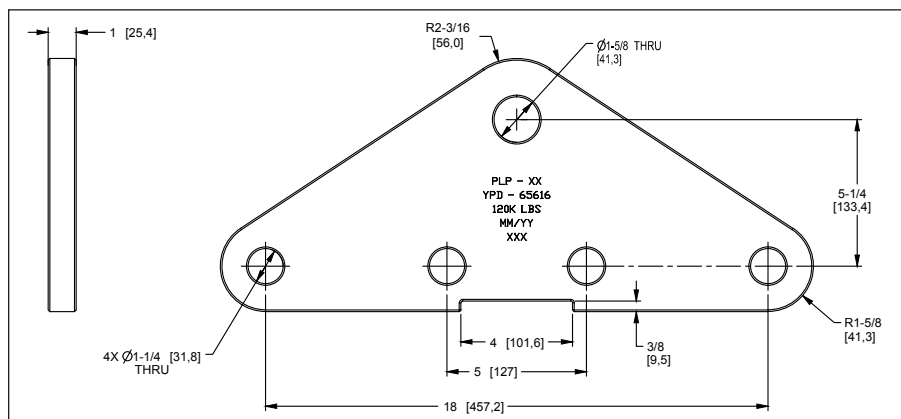
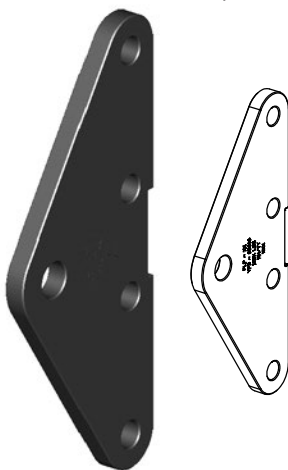

Notes

Material	Galvanized steel
Approximate weight	33 lbs (15 kg)
Rated breaking strength (RBS)	120,000 lbs (APEX Hole) (533 kN)



Transmission Line String Hardware

Yoke Plate for Double AGS

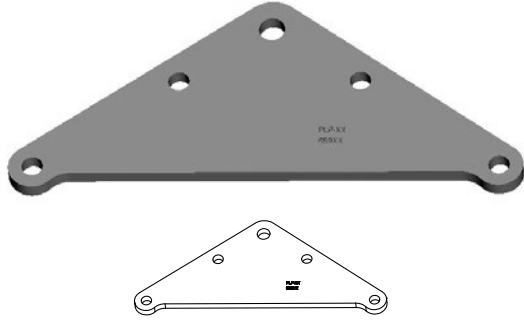

Material
Galvanized steel

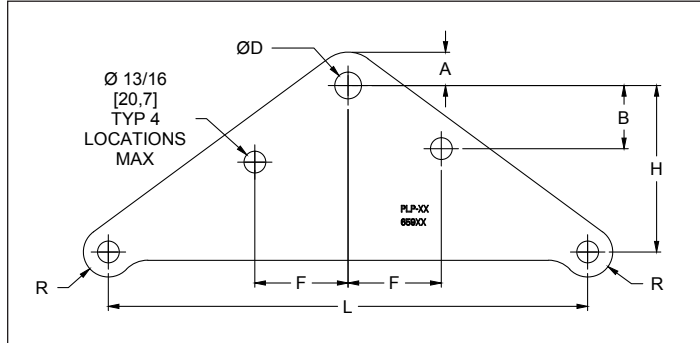

Catalog Number	General Dimensions inches (mm)							Plate Thickness Inches (mm)	Vertical Ultimate Strength lbf (kN)	Weight lbs (kg)
	A	B	D	F	H	L	R			
YP-5907	1 (25.4)	None	13/16 (20.6)	NONE	4 (101.6)	12 (305)	13/16 (20.6)	1/2 (12.7)	30,000 (133)	15.6 (7)
YP-5908	1-1/4 (31.8)	2-3/8 (60.5)	1 (25.4)	3-1/2 (88.9)	6-1/4 (158.6)	18 (457)	15/16 (23.8)	5/8 (15.9)	40,000 (178)	20.8 (9.4)
YP-5909	1-1/4 (31.8)	2-3/4 (69.9)	1 (25.4)	4-3/16 (106.4)	7-1/4 (184.2)	22 (559)	15/16 (23.8)	5/8 (15.9)	40,000 (178)	33.1 (15)
YP-5910	1-1/4 (31.8)	3-1/4 (82.6)	1 (25.4)	4-15/16 (125.4)	8-1/2 (215.9)	26 (660)	15/16 (23.8)	3/4 (19.1)	50,000 (222)	40.3 (18.3)
YP-5911	1-1/4 (31.8)	3-5/8 (92.1)	1 (25.4)	5-1/2 (139.7)	9-1/2 (241.3)	29 (737)	15/16 (23.8)	3/4 (19.1)	50,000 (222)	48.1 (21.8)
YP-5912	1-1/4 (31.8)	4 (101.6)	1 (25.4)	6-1/8 (155.6)	10-1/2 (266.7)	32 (813)	15/16 (23.8)	3/4 (19.1)	50,000 (222)	59.8 (27.1)
YP-5913	1-1/4 (31.8)	4-1/2 (114.3)	1 (25.4)	7-1/16 (180.9)	11-3/4 (298.5)	37 (940)	15/16 (23.8)	3/4 (19.1)	50,000 (222)	59.9 (27.2)
YP-5934	1-1/4 (31.8)	5 (127)	1 (25.4)	7-27/32 (199.2)	13 (330.2)	42 (1066.8)	15/16 (23.8)	3/4 (19.1)	50,000 (222)	76 (34.5)

Transmission Line String Hardware

Yoke Plate, Rectangle, 30K (Per Hole) – Catalog No. YPR-65606

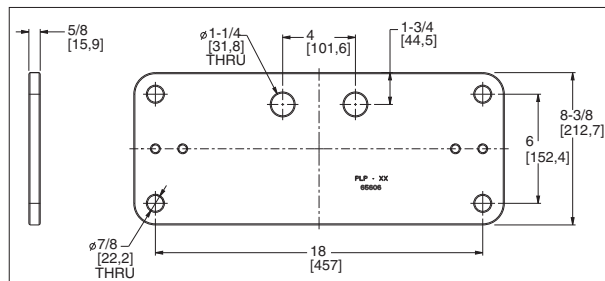
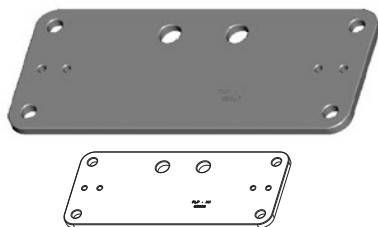

Notes	
Material	Galvanized steel
Approximate weight	29 lbs (13.2 kg)
Rated breaking strength (RBS)	30,000 lbs (133 kN)

Yoke Plate, Rectangle, 50K (Per Hole) – Catalog No. YPR-65608

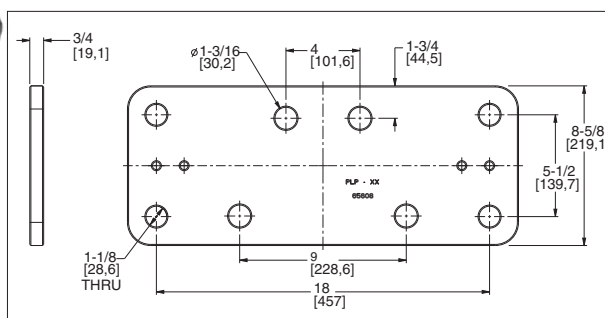
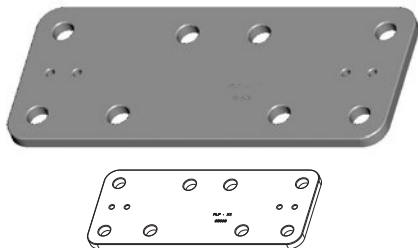

Notes	
Material	Galvanized steel
Approximate weight	36 lbs (16.3 kg)
Rated breaking strength (RBS)	50,000 lbs (222 kN)

Yoke Plate, Rectangle, 80K (Per Hole) – Catalog No. YPR-65614

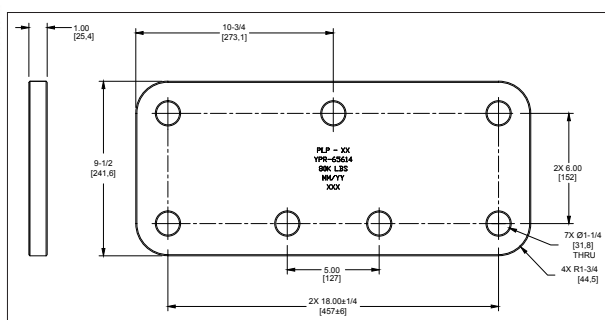
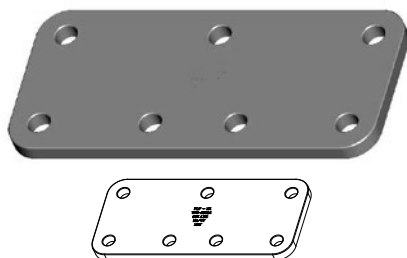

Notes	
Material	Galvanized steel
Approximate weight	36 lbs (16.3 kg)
Rated breaking strength (RBS)	50,000 lbs (222 kN)



Transmission Line String Hardware

4" (101mm) Yoke Plate, Delta, 30K (Per Hole) – Catalog No. YPD-65623

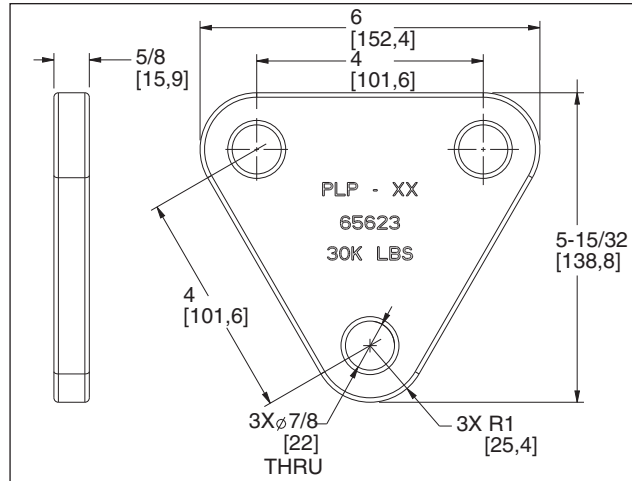
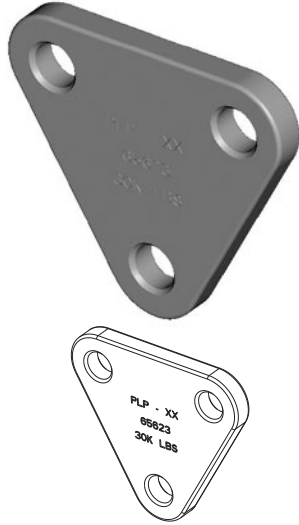

Notes	
Material	Galvanized steel
Approximate weight	4 lbs (1.81 kg)
Rated breaking strength (RBS)	30,000 lbs (133 kN)

4" (101mm) Yoke Plate, Delta, 50K (Per Hole) – Catalog No. YPD-65624

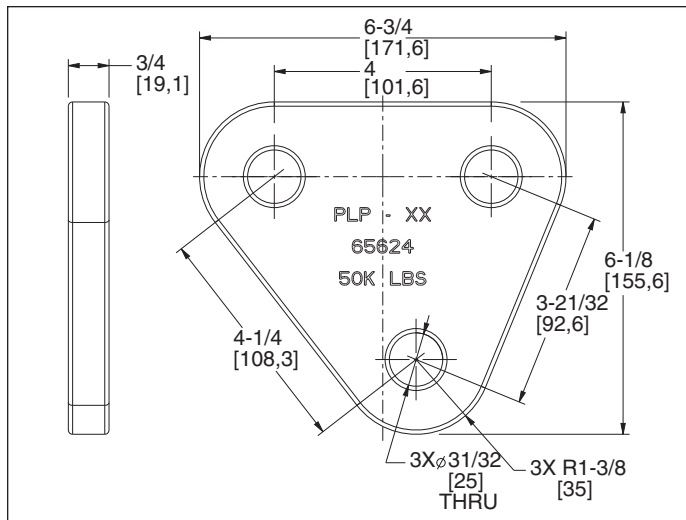
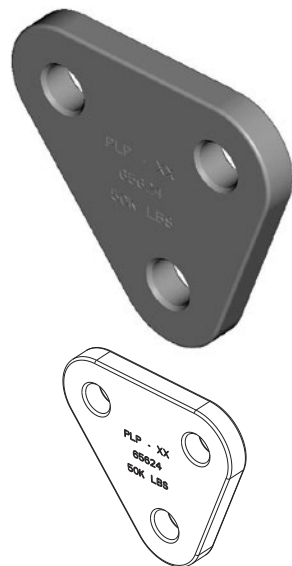

Notes	
Material	Galvanized steel
Approximate weight	6 lbs (2.72 kg)
Rated breaking strength (RBS)	50,000 lbs (222 kN)

Transmission Line String Hardware

Yoke Plate, Delta, 30K – Catalog No. YPD-65643

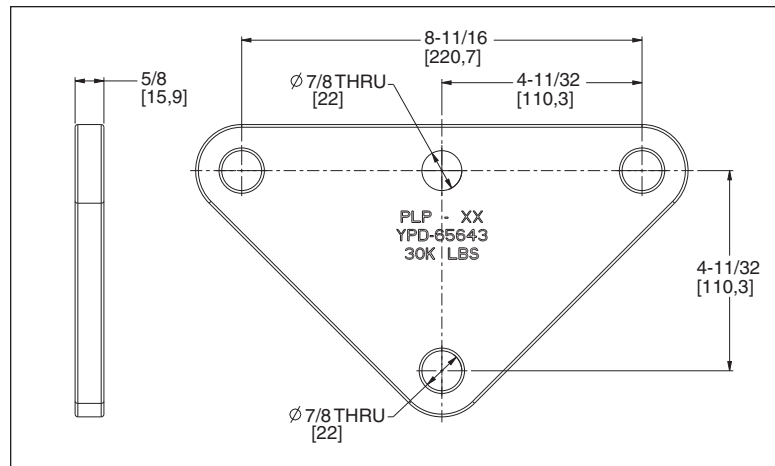
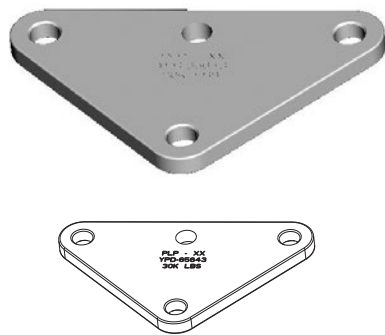

Notes

Material	Galvanized steel
Approximate weight	7 lbs (3.2 kg)
Rated breaking strength (RBS)	30,000 lbs (133 kN)

Yoke Plate, Delta, 100K – Catalog No. YPD-65972

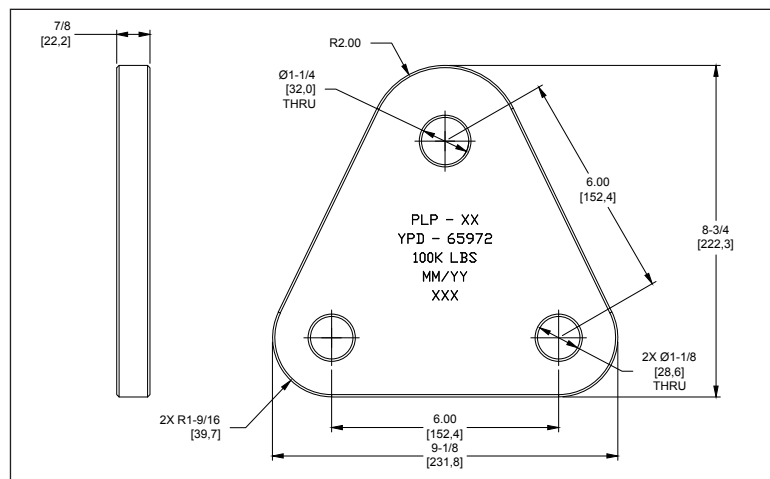
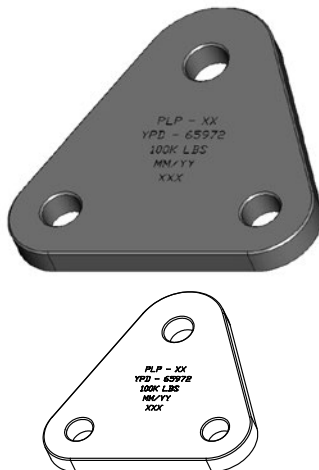

Notes

Material	Galvanized steel
Approximate weight	13 lbs (5.9 kg)
Rated breaking strength (RBS)	100,000 lbs (444 kN)



Transmission Line String Hardware

Yoke Plate, V-String Twin, 30K (Per Hole) – Catalog No. YPV-65611

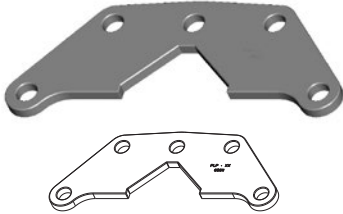

Notes	
Material	Galvanized steel
Approximate weight	19 lbs (8.6 kg)
Rated breaking strength (RBS)	30,000 lbs (133 kN)

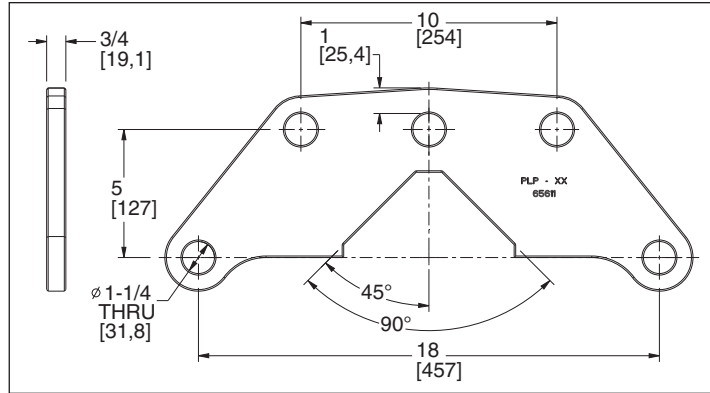

Yoke Plate, V-String Twin, 50K (Per Hole) – Catalog No. YPV-65617

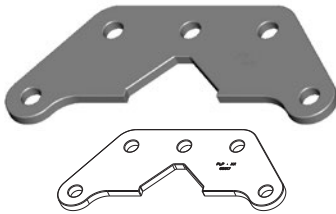

Notes	
Material	Galvanized steel
Approximate weight	23 lbs (10.4 kg)
Rated breaking strength (RBS)	50,000 lbs (222 kN)

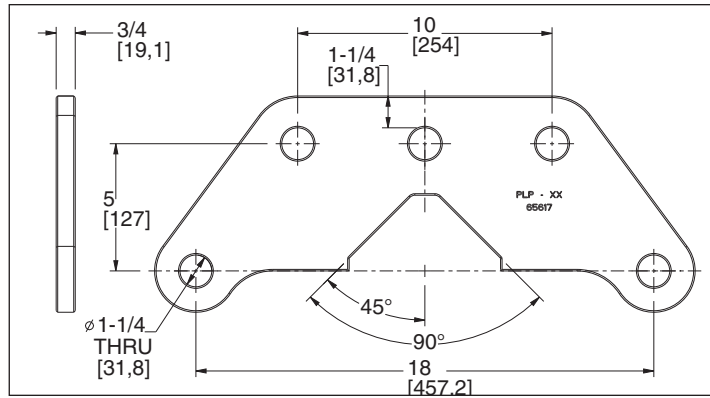

Yoke Plate, Medium Angle, 50K (Per Hole) – Catalog No. YPC-65613

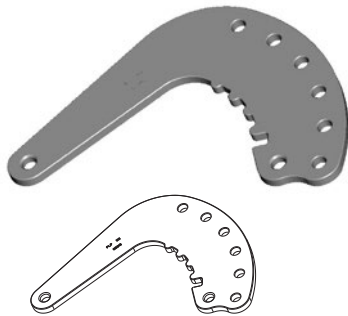

Notes	
Material	Galvanized steel
Approximate weight	34 lbs (15.4 kg)
Rated breaking strength (RBS)	50,000 lbs (222 kN)

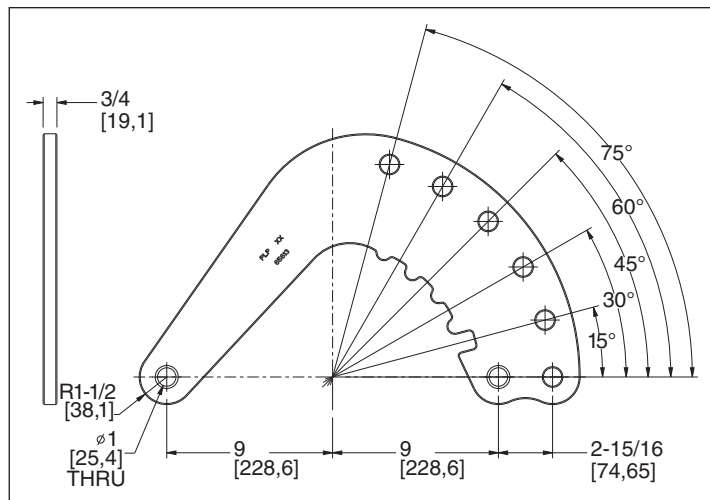

Transmission Line String Hardware

Yoke Plate, Crescent, 30K (Per Hole) – Catalog No. YPC-65958

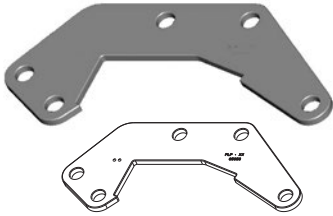

Notes	
Material	Galvanized steel
Approximate weight	20 lbs (9.1 kg)
Rated breaking strength (RBS)	30,000 lbs (133 kN)

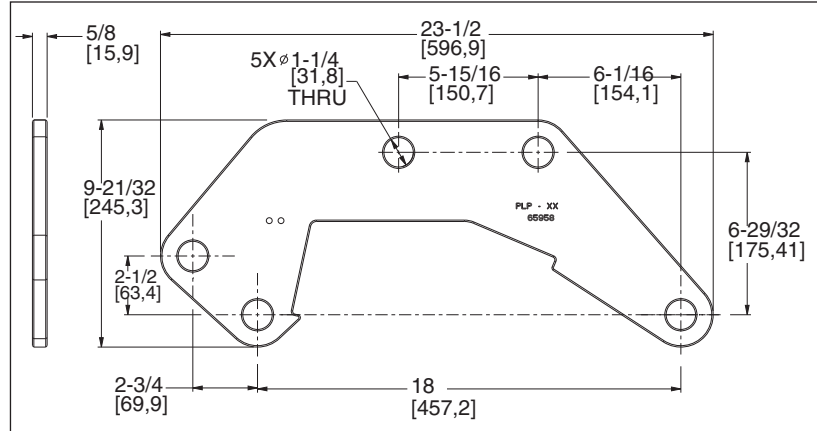

Yoke Plate, Crescent, 50K (Per Hole) – Catalog No. YPC-65962

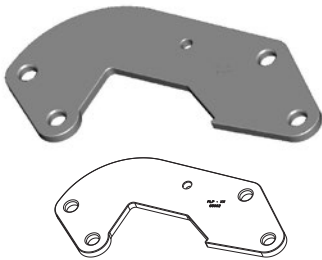

Notes	
Material	Galvanized steel
Approximate weight	33 lbs (15 kg)
Rated breaking strength (RBS)	50,000 lbs (222 kN)

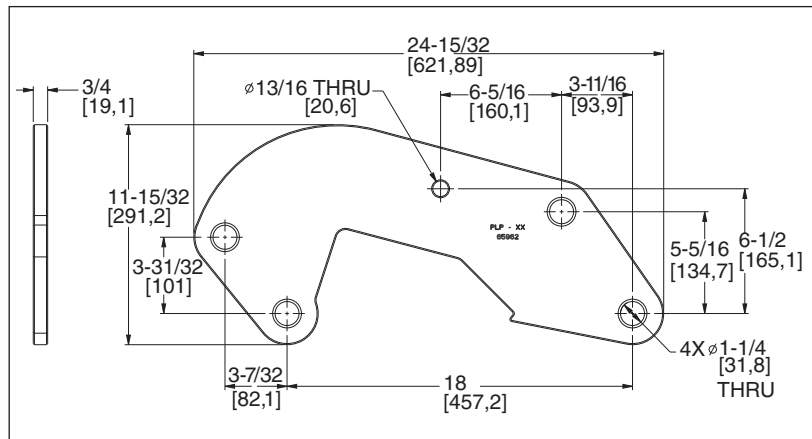



Transmission Line String Hardware

Yoke Plate Semi-V 60/30 – 30K (Per Hole) – Catalog No. YPD-65641

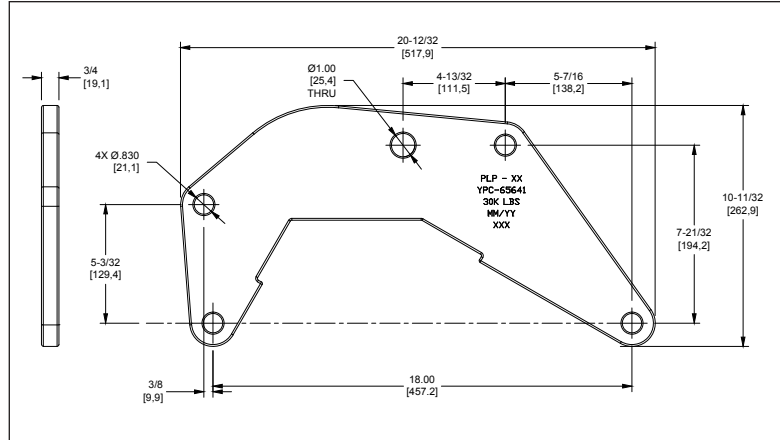
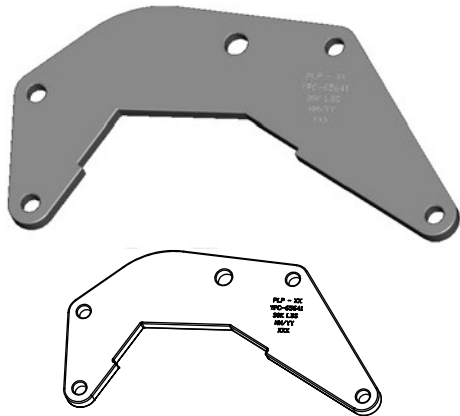

Notes	
Material	Galvanized steel
Approximate weight	22 lbs (9.9 kg)
Rated breaking strength (RBS)	30,000 lbs (135 kN)

Yoke Plate Semi-V 78/12 – 30K (Per Hole) – Catalog No. YPD-65642

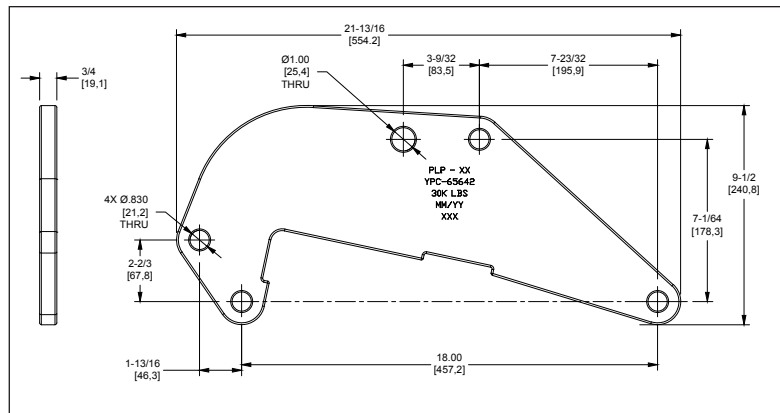
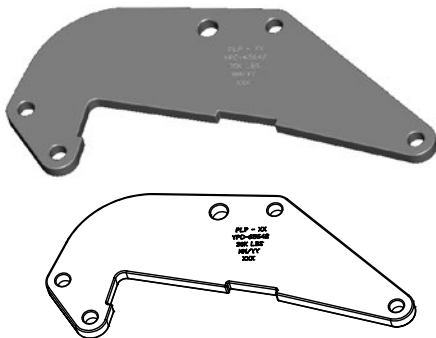

Notes	
Material	Galvanized steel
Approximate weight	24 lbs (15 kg)
Rated breaking strength (RBS)	30,000 lbs (133 kN)

Transmission Line String Hardware

Cross Reference

Description	PLP-US Cat. No.	Anderson Equiv.	MacLean Equiv.	Lindsey Equiv.
Anchor Shackle BNK, 30K	AS-30BNK	AS-25BNK	ASH-55 BC	3231 BNC
Anchor Shackle, 30K	AS-5L	AS-25	ASH-55	3231
Anchor Shackle BNK, 50K	AS-50BNK	AS-50	ASH-67-BC	3269 BNC
Anchor Shackle BNK, 70K	AS-70BNK	NA	ASH-77-BC	3262A BNC (72K)
Anchor Shackle, BNK, 100K	AS-100BNK	97674-3001	ASH-89-BC	3264 BNC
Ball Clevis, 30K	BC-30	BC-30	CB-55	3075
Ball Clevis, 50K	BC-50	BC-50	CB-78	3079
Ball Clevis Link, 30K	BCL-30	HBC-30	CBHL-55A	3441
Ball Clevis Link, 50K	BCL-50	HBC-50	CBHL-78	NA
Ball Eye	BE-30	BE-30	OEB-55	3302
Ball Eye	BE-50	90946-2000	OEB-68	3303
Ball Eye Link, 30K, Length May Vary	BEL-30-xx	HOEB-30-L	OEBHL-55	3452
Ball Eye Link, 50K, Length May Vary	BEL-50-xx	HOEB-50-L	NA	NA
Ball Hook, 25K	BH-25	HB30L (30K)	HB-5L (30K)	3311 (30K)
Ball Y-Clevis, 30K	BYC-30	YBC-30	YCB-65A	3089
Ball Y-Clevis, 50K	BYC-50	YBC-50	YCB-78	3094
Ball Y-Clevis Link, 30K	BYCL-30	HYBC-30	YCBHL-65A	3491
Ball Y-Clevis Link, 50K	BYCL-50	HYBC-50	YCBHL-78	3444
Rotated Clevis Clevis, 30K	CC-30-90	NA	NA	3121
Clevis Clevis, 30K	CC-30	CCC30115	NA	3001
Clevis Clevis, 40K	CC-40	CCC40	NA	3063
Clevis Eye, 25K	CE-5107	CA101	NA	3311/3051
Clevis Eye, 30K, Rotated	CE-30-90	NA	NA	3109
Clevis Eye, 50K, Rotated	CE-50-90	NA	RCE-66-812 (40K)	3122 (40K)
Clevis Eye	CE-5105	CA-10-13	RCE-55-1125	NA
Clevis Eye	CE-5106	CA-22-13	SCE-55-1125	NA
Clevis Eye	CE-5259	CA-04	NA	3310
Clevis Eye	CE-5261	CA-05	RCE-55-750A	NA
Clevis Eye, 30K	CE-30	NA	NA	NA
Clevis Extension Link, 15-3/4" (400mm), 30K	CEL-30-15	82910-200	SCEL-55-687C	3478
Chain Link, 30K	CL-30	LK-30	CL-4	3402
Chain Link, 60K	CL-60	LK-60	CL-6	3405
Chain Link, 80K	CL-80	LK-80	CL-8	NA
Chain Link, 100K	CL-100	LK-150	CL-8	3406
Chain Link, 120K	CL-120	LK-150	NA	NA
Eye Eye Link, 30K, 7"	EEL-7	NA	NA	3484/7
Eye Eye Link, 30K, Length May Vary	EEL-30-xx	HOO-30L	LOO-55-L	3484/L
Eye Eye Link, 50K, Length May Vary	EEL-50-xx	HOO-50L	LOO-77-L	NA
Eye, Y-Clevis Link, 30K	EYCL-30-12	NA	NA	NA
Extension Strap, 30K, Length May Vary	ES-30-xx	ES-30-7819-L	NA	NA
Extension Strap, 50K, Length May Vary	ES-50-xx	NA	NA	NA
Rotated Anchor Shackle, 25K	AS-25-90	NA	NA	NA
Rotated Anchor Shackle, 25K, BNK	AS-25-90BNK	NA	NA	NA
Rotated Clevis Eye, 30K	CE-30-90	CE0034-10	RCE-66-1125	3190
Socket Clevis	SC-5194	SC-30	SCR-55	3182
Socket Clevis	SC-5329	SC-50	SCR-87	NA
Socket Clevis Link, 30K	CSL-30	HSC100	SCHL-55	NA
Socket Clevis Link, 50K	CSL-50	HSC11501	SCHL-87	NA

NOTE: Some dimensions and ratings may vary between the listed products (see catalog information for exact details).



Transmission Line String Hardware

Cross Reference continued

Description	PLP-US Cat. No.	Anderson Equiv.	MacLean Equiv.	Lindsey Equiv.
Socket Eye	SE-5150	SA-04	SI-500	3349
Socket Eye	SE-5152	SA-06	SI-750	3350
Socket Eye	SE-5154	SA-10	SE-1000-6	3355
Socket Eye	SE-5155	SA-21-13	SE-2000-6	3367
Socket Eye	SE-5156	NA	NA	NA
Socket Eye, 30K	SE-5157	SA-11	SI-1125	3354
Socket Eye, 50K	SE-5158	NA	SE8-3250-7	NA
Socket Eye, 50K	SE-9002	90612000	SE8-1437-7	3385
Socket Eye Link, 30K, 9-1/2" (241mm) w.l.	SEL-30	HSE-100-10	SCHL-55A	3463
Socket Y-Clevis, 30K	SYC-30	SYC-30	SYCR-56	3340
Socket Y-Clevis, 50K	SYC-50	SYC-50	SYCR-87	3343
Socket Y-Clevis Link, 30K	SYCL-30	HYSC-30	SYCHL-56A	3472
Socket Y-Clevis Link, 50K	SYCL-50	HSYC-50	SYCHL-87	3471
CGS Vertical Bundling Links	VBLMS11244	NA	NA	NA
CGS Vertical Bundling Links	VBLMS11302	NA	NA	NA
Y-Clevis Eye	YC-5206	YCS-05-90	NA	NA
Y-Clevis Eye	YC-5207	YCS-06-90	NA	NA
Y-Clevis Eye	YC-5209	YCS-06-90	NA	3127
Y-Clevis Eye	YC-5211	YCS219013	NA	NA
Y-Clevis Eye, 25K	YC-5212	YCS-06-09	NA	NA
Y-Clevis Clevis, 30K	YCC-30	YCC-30	YCC-65	3191
Y-Clevis Eye, 50K	YCE-50	NA	NA	NA
Y-Clevis Y-Clevis Link, 50K	YCYC-50	NA	YCYCHL-77	3434/L
AGS Yoke	YP-5907	NA	NA	NA
AGS Yoke	YP-5908	NA	NA	NA
AGS Yoke	YP-5909	NA	NA	NA
AGS Yoke	YP-5910	NA	NA	NA
AGS Yoke	YP-5911	NA	NA	NA
AGS Yoke	YP-5912	NA	NA	NA
AGS Yoke	YP-5913	NA	NA	NA
Yoke Plate, Medium Angle, 50K per Hole	YPC-65613	YPC-50-9378	NA	NA
Yoke Plate, Crescent, 30K	YPC-65958	YPC-30-17424-1	N/A	N/A
Yoke Plate, Crescent, 50K	YPC-65962	945834005	N/A	N/A
Yoke Plate, Delta, 100K	YPD-65972	NA	NA	NA
Yoke Plate, Triangle, I-String or Dead-End, 40K	YPD-65597	YPD-40-18342-4	NA	3525
Yoke Plate, Triangle, Dead-End, 80K	YPD-65598	YPD-80-18475	Y2DT080S1800	3525 (60K)
Yoke Plate, Triangle, I-String or Dead-End, 50K	YPD-65607	YPD-50-18549-1	Y2DT060S1800	3572
Yoke Plate 4" (101mm), 30K, Triangle	YPD-65623	NA	Y1VS030S	NA
Yoke Plate 4" (101mm), 50K, Triangle	YPD-65624	NA	Y1V2050S	NA
Yoke Plate, Triangle, I-String, 50K	YPD-65961	YPD-50-10785-3	Y1TT050S1800	3572
Yoke Plate, Triangle, 100K	YPD-65965	95154-4001	Y2DT100S1800	3525
Yoke Plate, Triangle, 120K	YPD-65616	NA	NA	NA
Yoke Plate, Rectangle, 80K	YPR-65614	NA	NA	NA
Yoke Plate, Rectangle, Dead-End, 30K per Hole	YPR-65606	97611-3002	Y2DR060S1800	NA
Yoke Plate, Rectangle, Dead-End, 50K per Hole	YPR-65608	92933-3002	Y2DR060S1800	3536CB
Yoke Plate, Semi-V 60/30, 30K	YPC-65641	NA	NA	NA
Yoke Plate, Semi-V 78/12, 30K	YPC-65642	NA	NA	NA
Yoke Plate, V-String, Twin, 30K per Hole	YPV-65611	YPV-30-17259-2	Y2VS030S1845	3580
Yoke Plate, V-String, Twin, 50K	YPV-65617	93006-4004	Y2VS050S1845	3582

NOTE: Some dimensions and ratings may vary between the listed products (see catalog information for exact details).